

# Panasonic

INSTALLATION WORK



## ***TECHNICAL SEMINAR***

# ***INSTALLATION WORK***

- *Installation instructions.*
- *Distribution joint kits.*
- *Drainage work.*
- *Electrical wiring.*

# ***Installation instructions outdoor***



### *Selecting the Installation Site for Outdoor Unit*

#### **AVOID**

- Heat sources, exhaust fans, etc.
- Damp, humid or uneven locations
- Indoor (no-ventilation location)

#### **DO**

- Choose a place as cool as possible
- Choose a place that is well ventilated
- Allow enough room around the unit for air intake/exhaust and possible maintenance

### Selecting the Installation Site for Outdoor Unit

\* Make a walk-in space behind the unit to erase maintenance and service

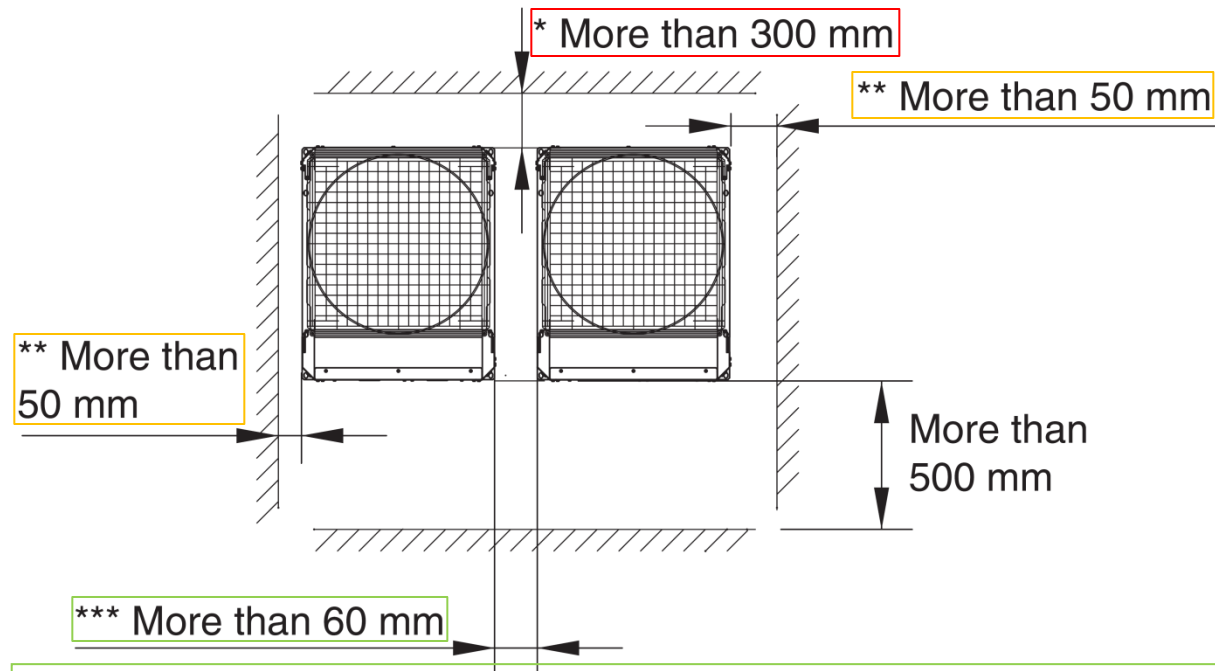

\*\* When setting the anchor bolt, make the space between the unit and the wall more than 250mm for installation operation.

\*\*\* When setting the anchor bolt, make the spare between the outdoor units more than 180mm for installation operation.

- Do NOT do any wiring or tubing within 30cm of the front panel, because this space is needed as a servicing space
- Ensure a base height of 100mm or more to ensure that drainage water dose not accumulate and damage the bottom of the unit.
- If installing a drain pan, install the drain pan make sure there is at least 150mm between the outdoor unit away from the ground. Also direction of the tubing and electrical wiring should be from the front of outdoor unit.

### Refrigerant tube port

Use caulking, putty, or a similar material to fill any gaps at the refrigerant tube port in order to prevent rainwater, dust or foreign substances from entering the unit.

\* Perform this work even if the tubing is routed out in a downward direction.

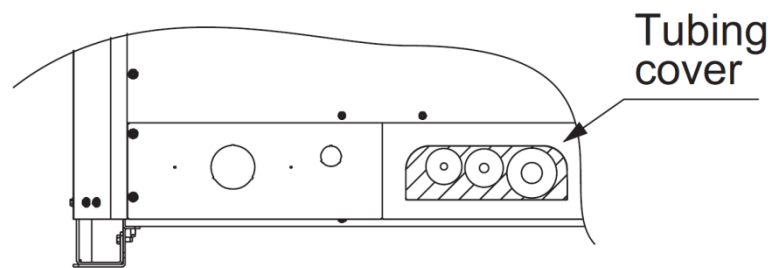

Tubing routed out through the front side

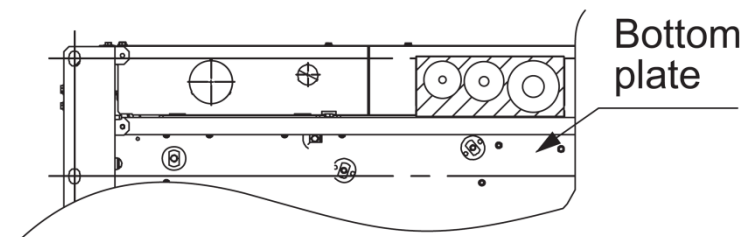

Tubing routed out through the bottom

### Tightening torque for each cap tightening torque

Service port cap (width 15 mm, 17 mm)		8 – 10 N · m (80 – 100 kgf · cm)
Valve cap	width 22 mm	19 – 21 N · m (190 – 210 kgf · cm)
	width 24 mm	24 – 26 N · m (240 – 260 kgf · cm)
	width 27 mm	28 – 32 N · m (280 – 320 kgf · cm)



# ***Installation instructions indoor***



### **Point to AVOID (Indoor Unit)**

- Area where leakage of flammable gas may be expected.
- Place where large amount of oil mist exist.
- Direct sunlight.
- Location where external air may enter the room directly. This may causing them to spray or drip.
- Location where the remote controller will be splashed with water or affected by dampness or humidity.
- Installing the remote controller behind curtains or furniture.
- Installing where high-frequency emissions are generated.
- Place where blocks air passages.
- Place where the false ceiling is not noticeably on an incline.





### **Point to TAKE NOTE (Indoor Unit)**

- Select an appropriate position from which every corner of the room can be uniformly cooled.
- Select a location where the ceiling is strong enough to support the weight of the unit.
- Select a location where tubing and drain pipe have the shortest run to the outdoor unit.
- Allow room for operation and maintenance as well as unrestricted the air flow around the unit.
- Install the unit within the maximum elevation difference above or below the outdoor unit within a total tubing length from the outdoor unit.
- Allow room for mounting the remote controller about 1m off the floor, in an area that is not in direct sunlight nor in the flow of cool air from the indoor unit. Air delivery will be degraded if the distance from the floor to the ceiling is greater than 3m (for L1 & D1 type, greater than 3.5m).
- Place where optimum air distribution can be ensured.
- Places where sufficient clearance for maintenance and service can be ensured.

### 1-Way Cassette Type (D1 Type)

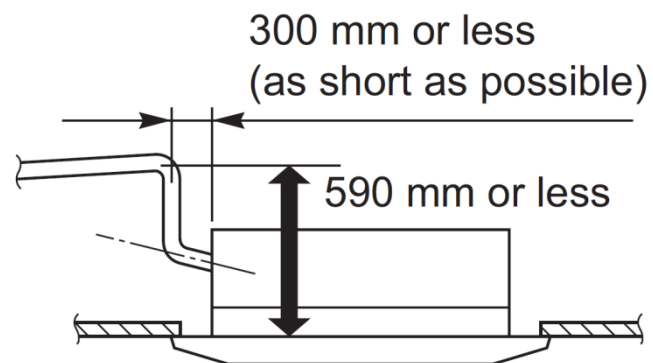
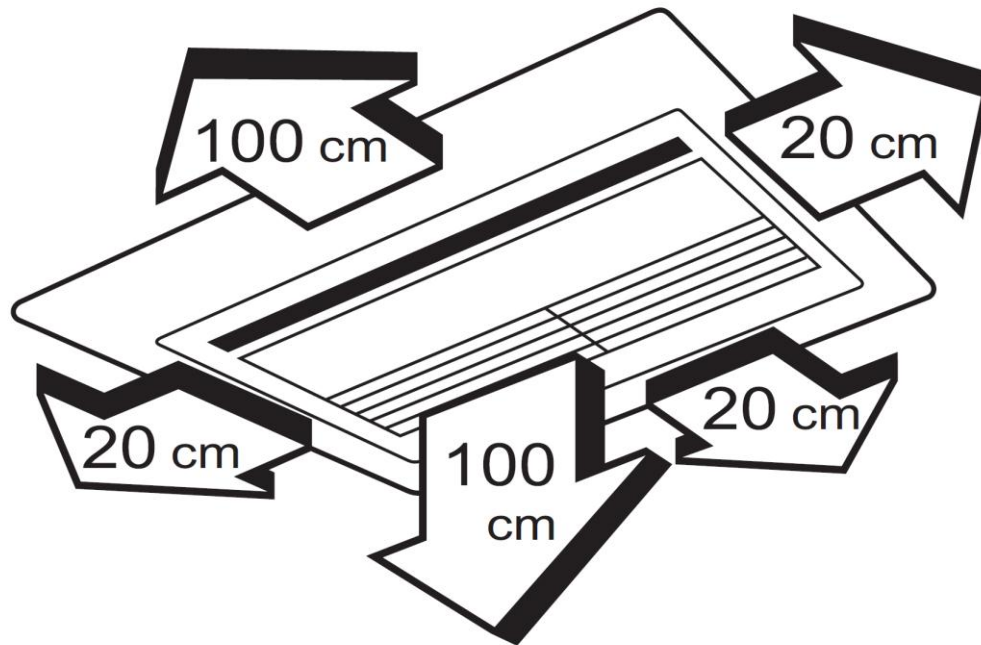

Air delivery will be degraded if the distance from the floor to the ceiling is greater than 3 m (for D1 type, greater than 3.5 m).

### 2-Way Cassette Type (L1 Type)

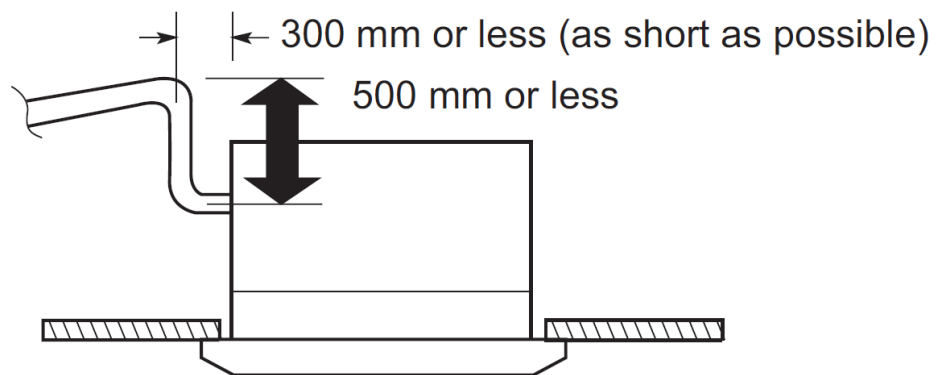
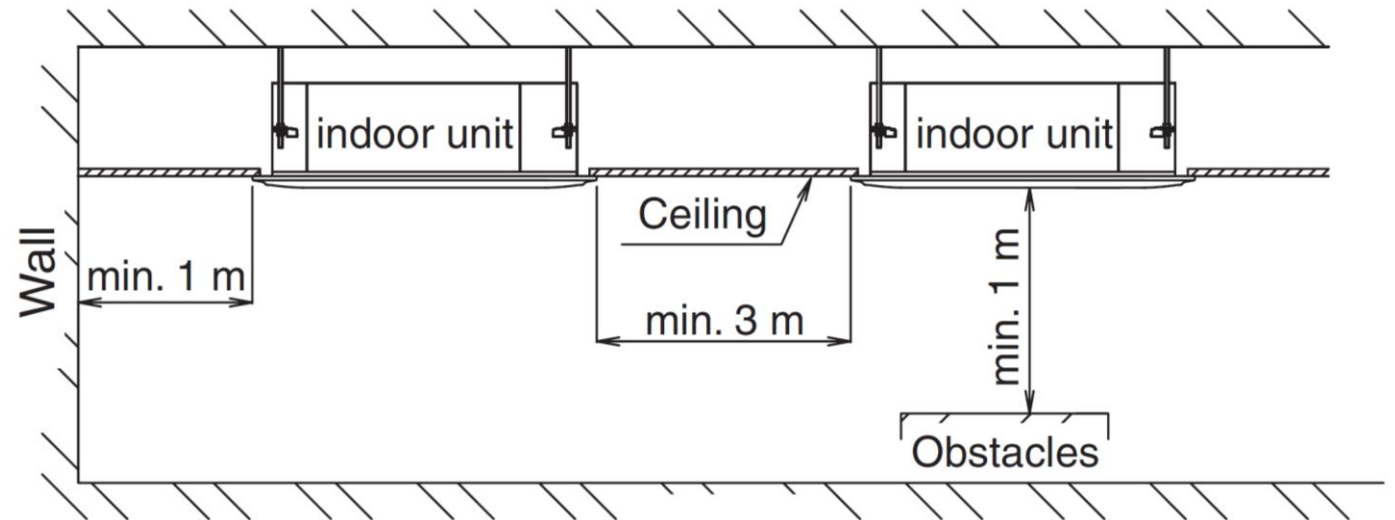
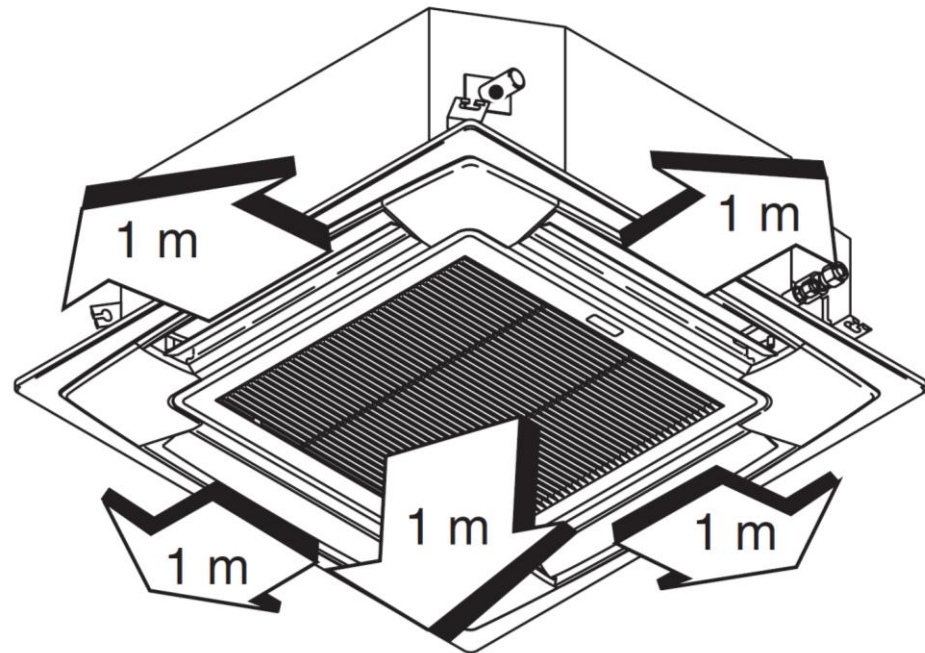

### 4-Way Cassette Type (U1 Type : S- \* \* MU1E51)

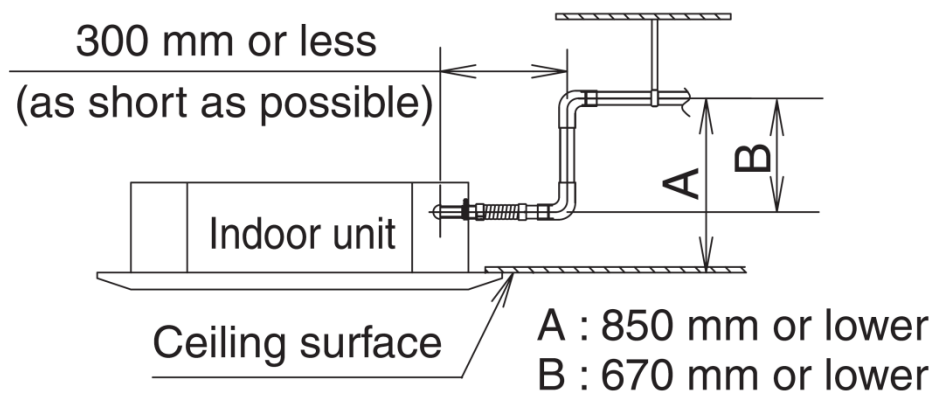
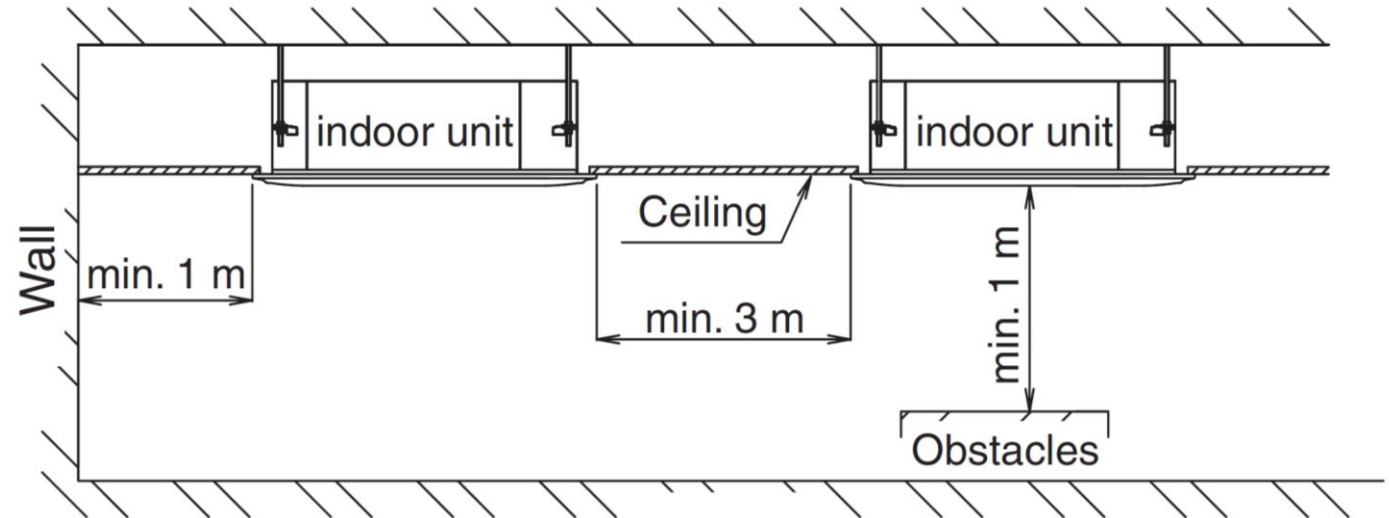
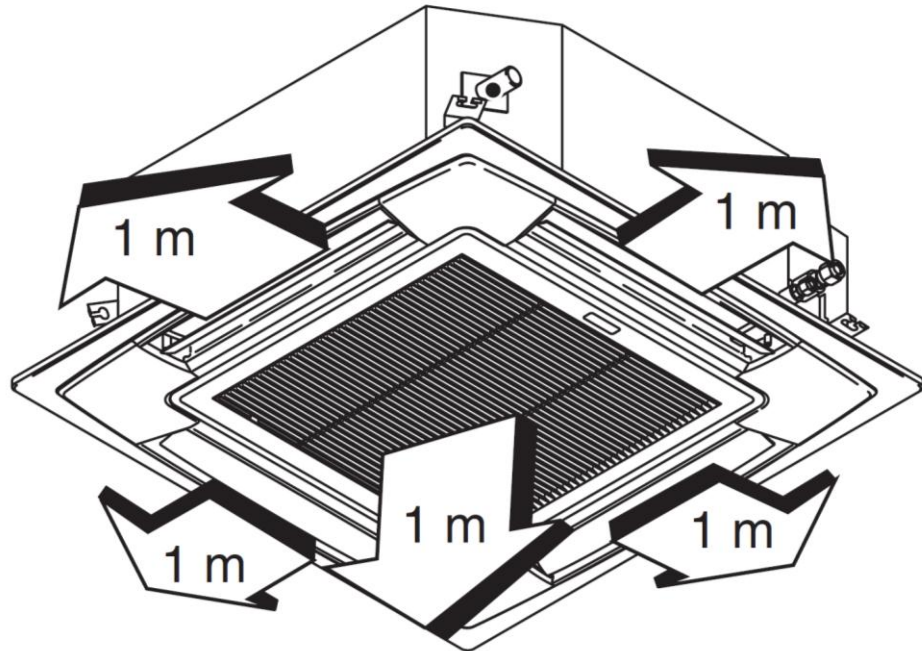

\* Length of supplied drain pipe = 250 mm

If the indoor unit is installed on the ceiling where the temperature or humidity inside is high (over 30°C/RH: 80%), add insulating material to the surface of the unit to avoid dew condensation. (Only for U1 type.)

### 4-Way Cassette 60x60 Type (Y1 Type)

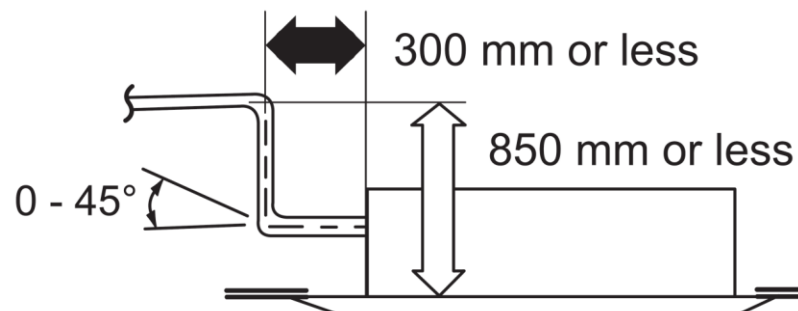
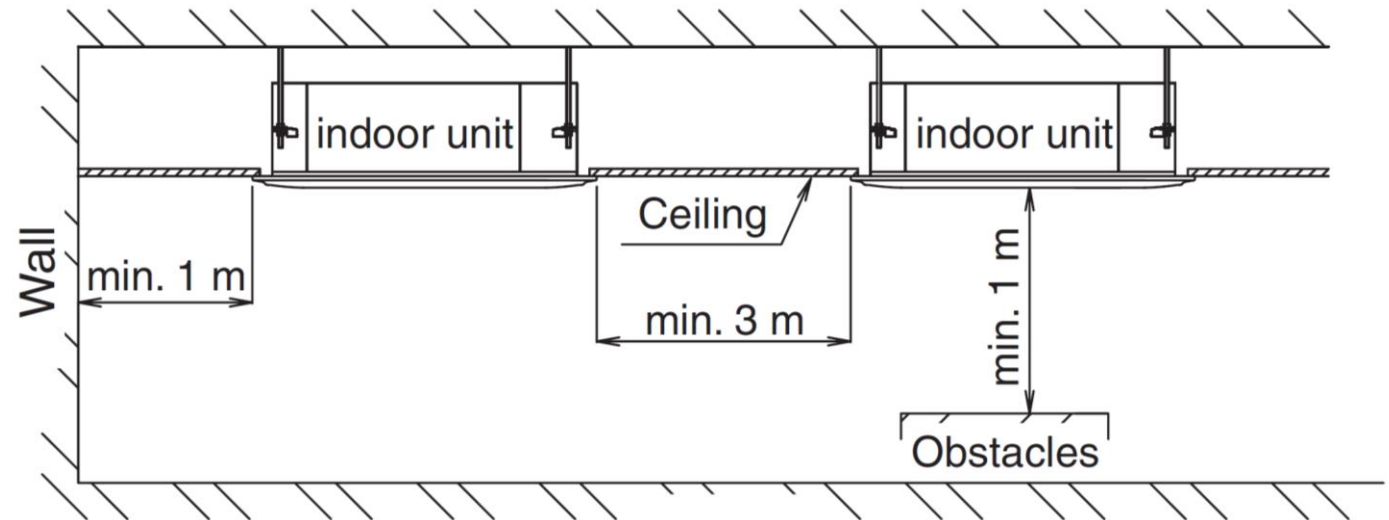
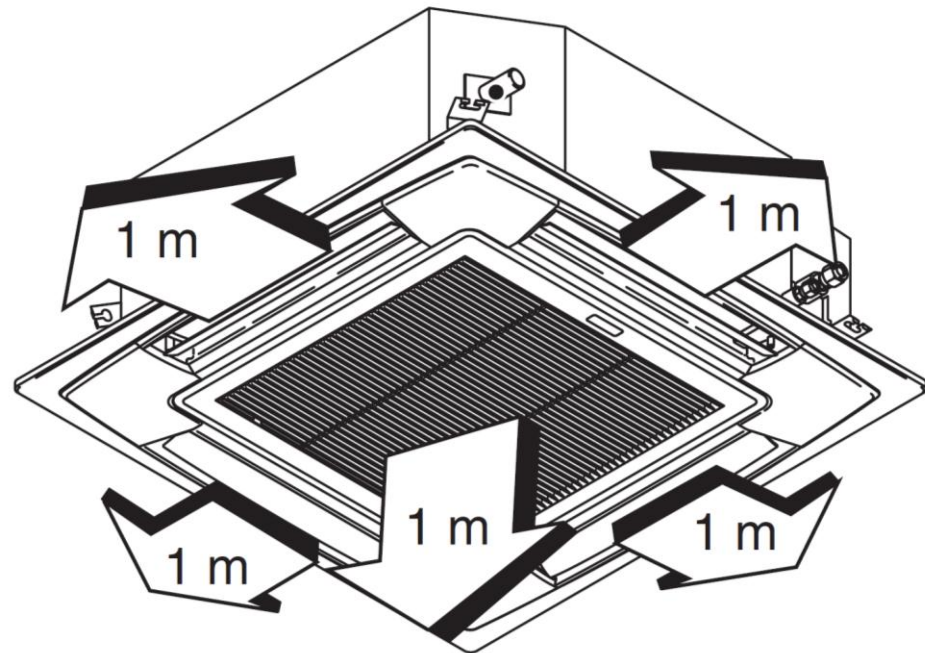

\* Length of supplied drain hose = 140 mm

### Ceiling Type (T1 Type)

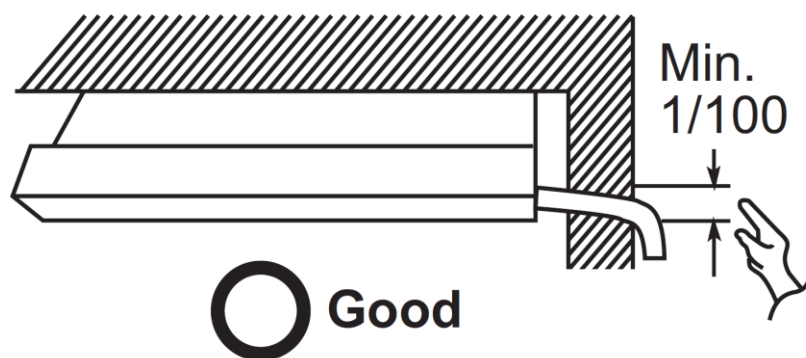
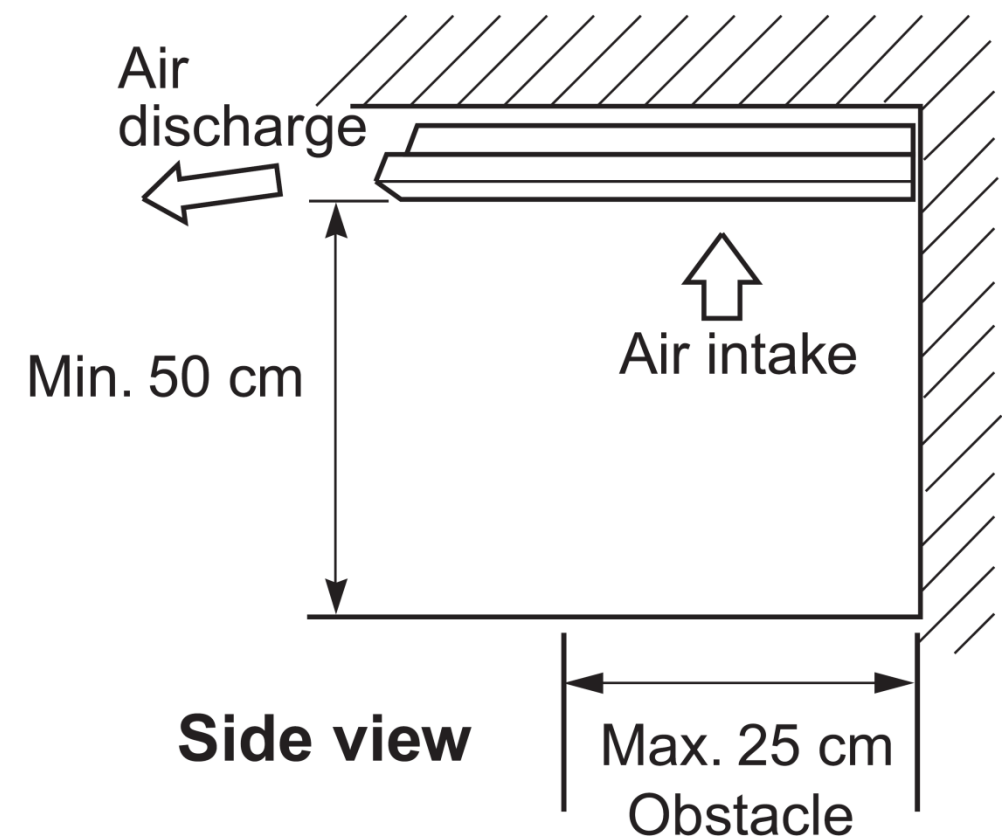
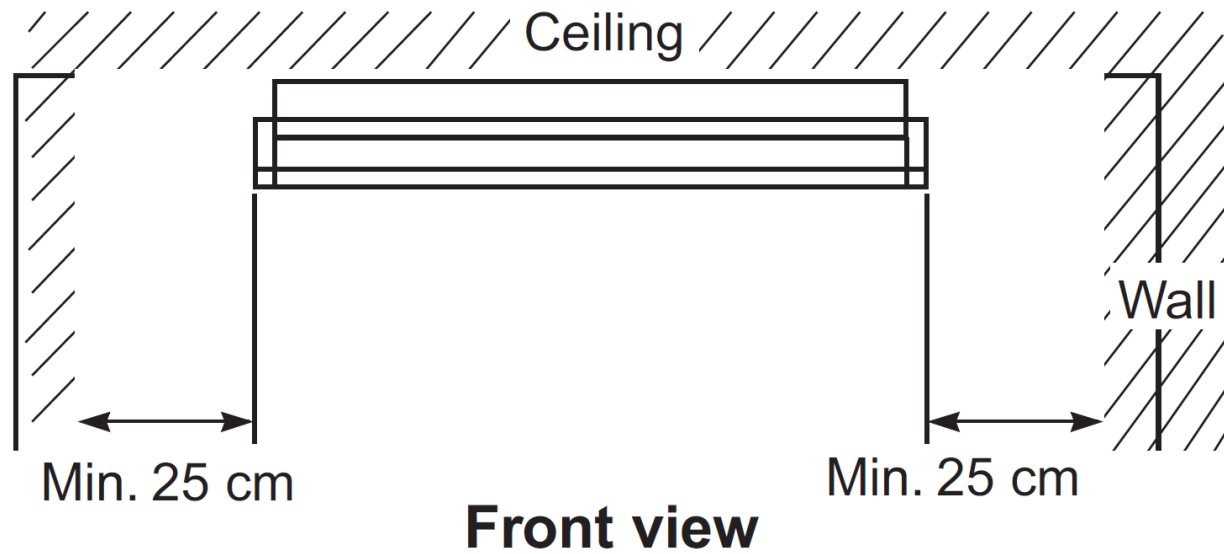

### Low Silhouette Ducted Type (F2 Type)

Unit: mm

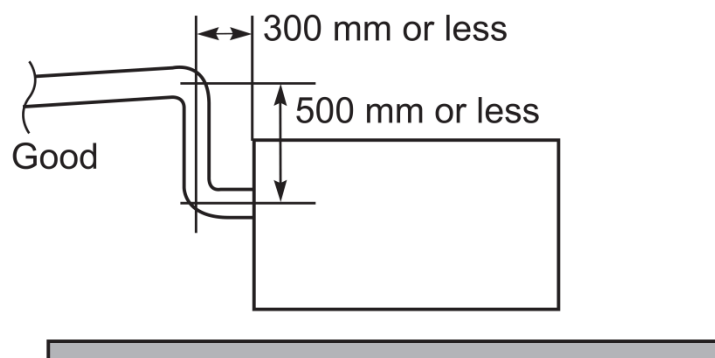
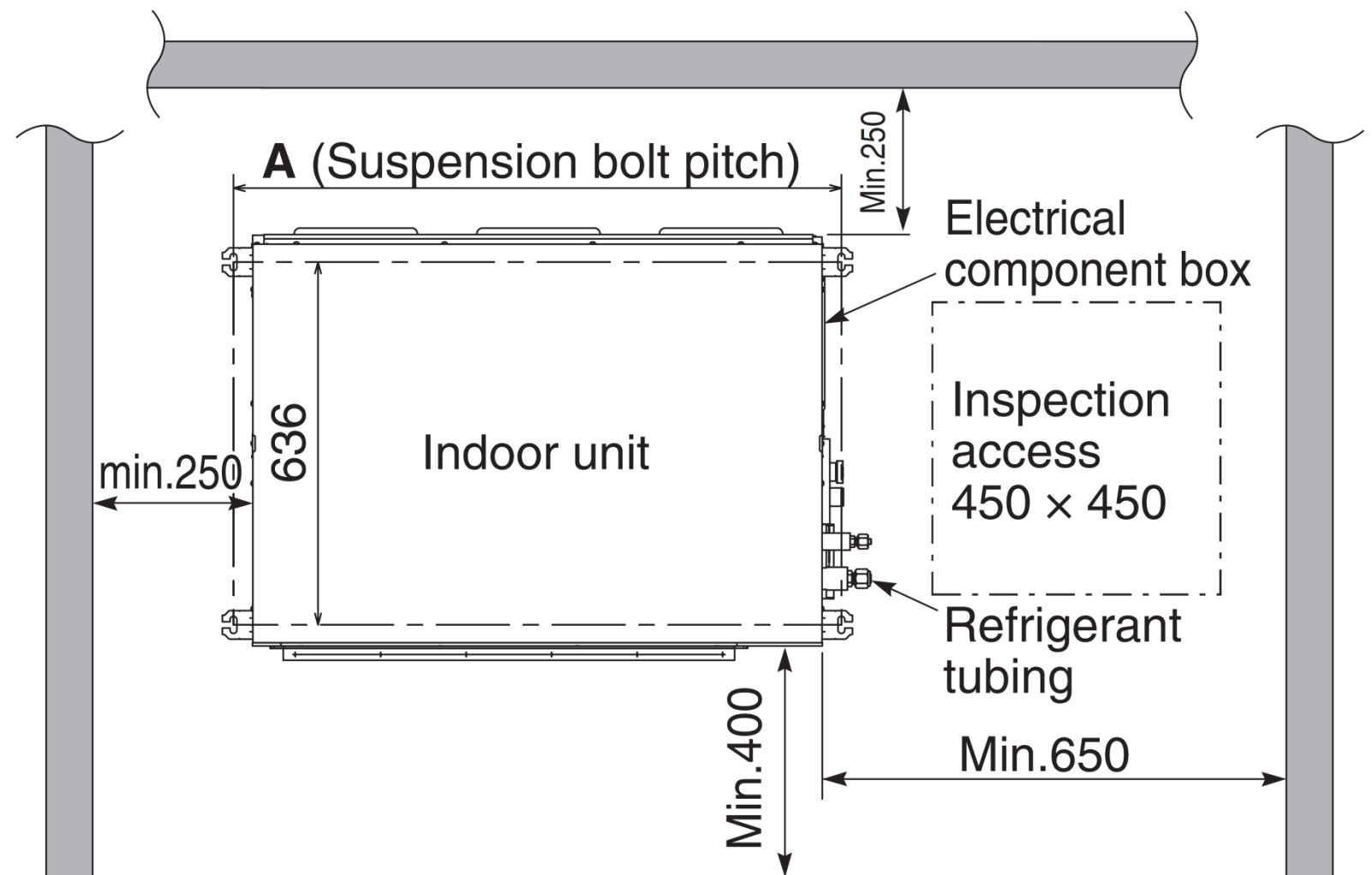

If the indoor unit is installed on the ceiling where the temperature or humidity inside is high (over 30°C/RH: 70%), add insulating material to the surface of the unit to avoid dew condensation. (Only for F2 type.)

### Slim Low Static Ducted Type (M1 Type)

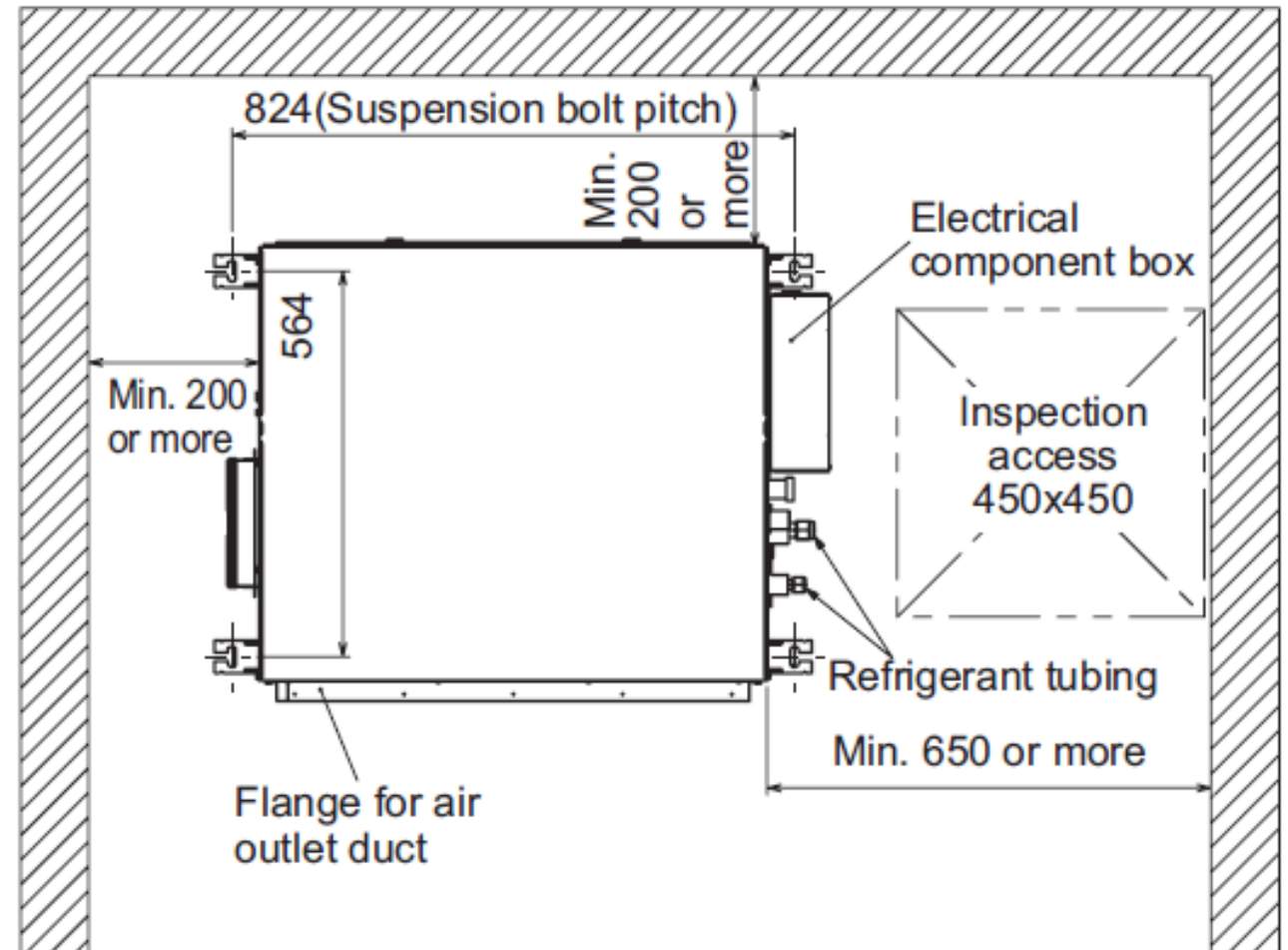
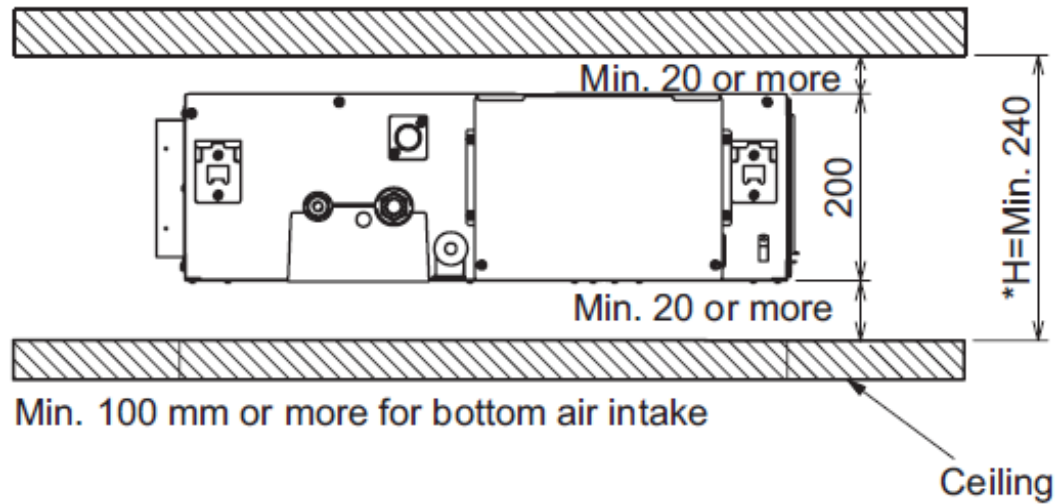

Unit: mm

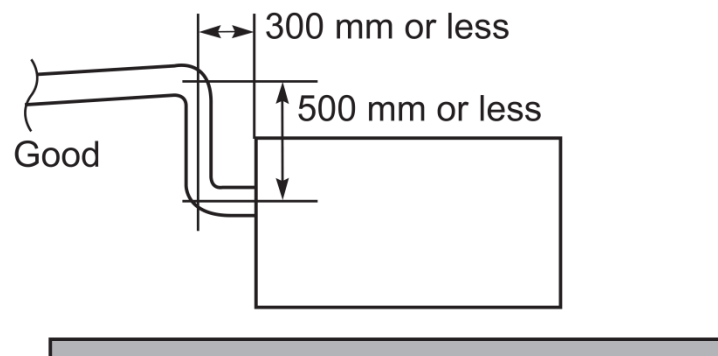



### High Static Pressure Ducted Type (E1 Type)

Unit: mm

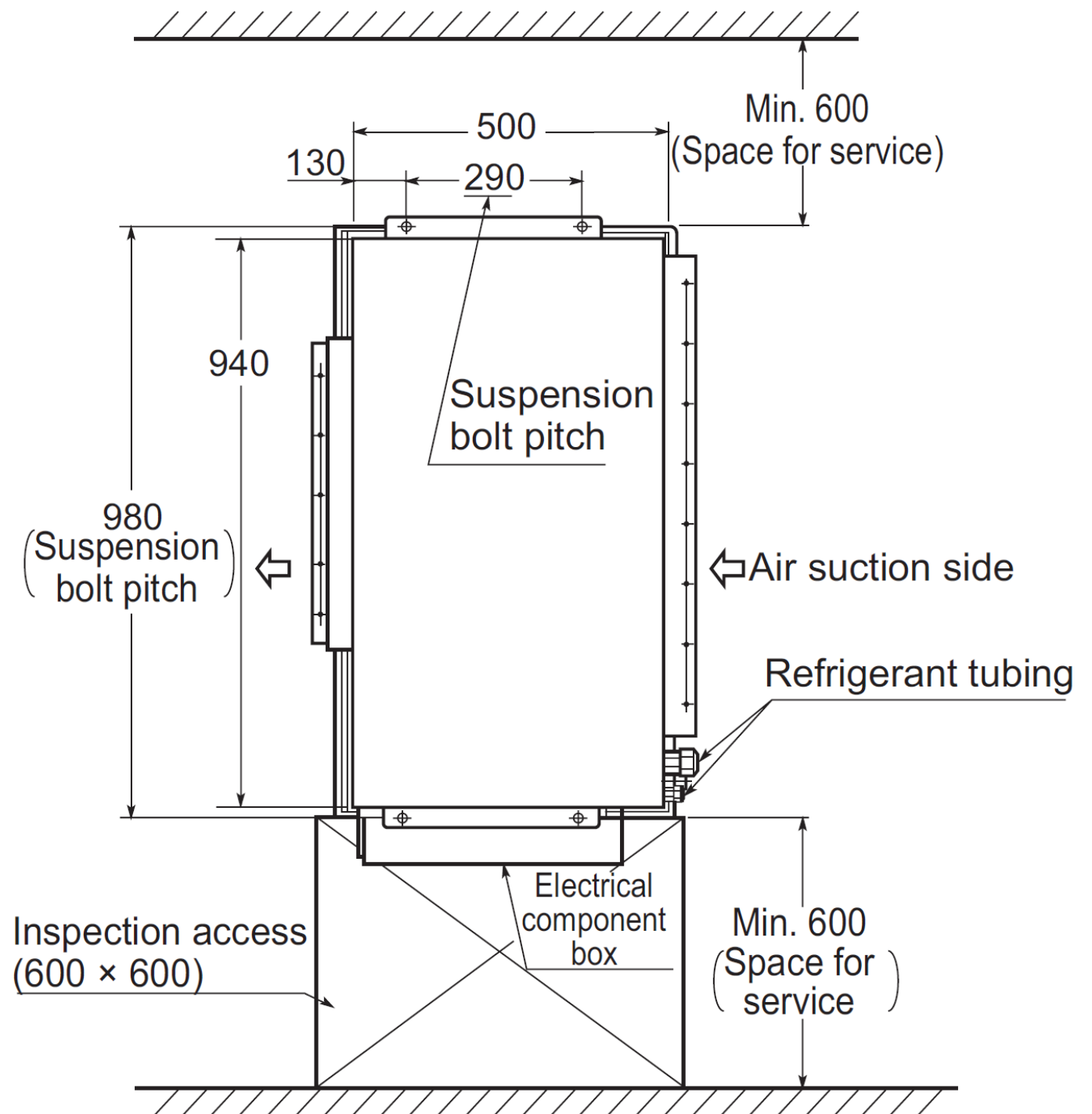
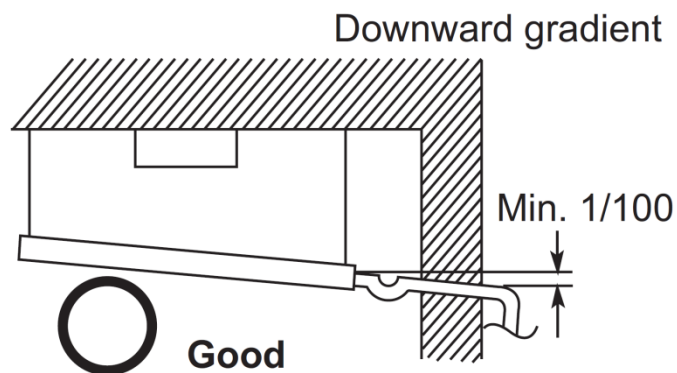
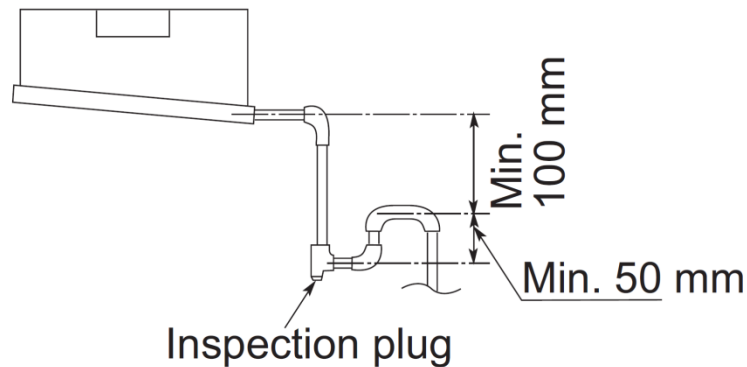
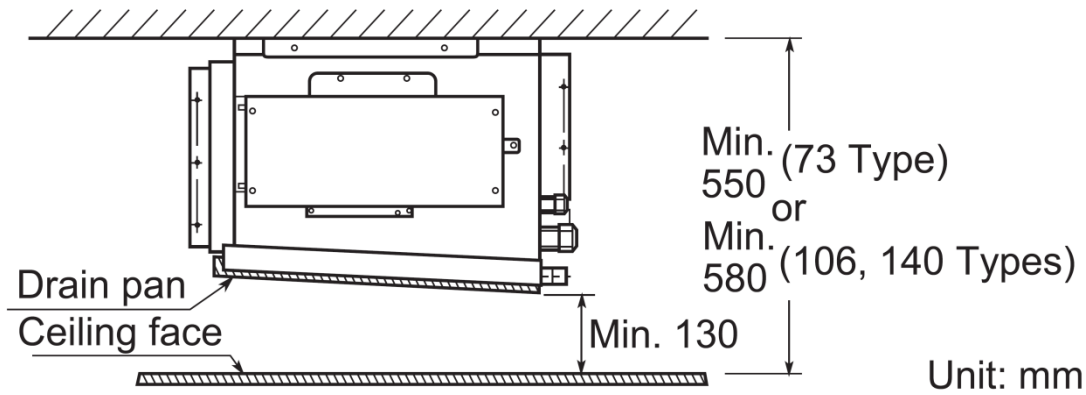

### High Static Pressure Ducted Type (E1 Type) (224, 280 Types)

Unit: mm

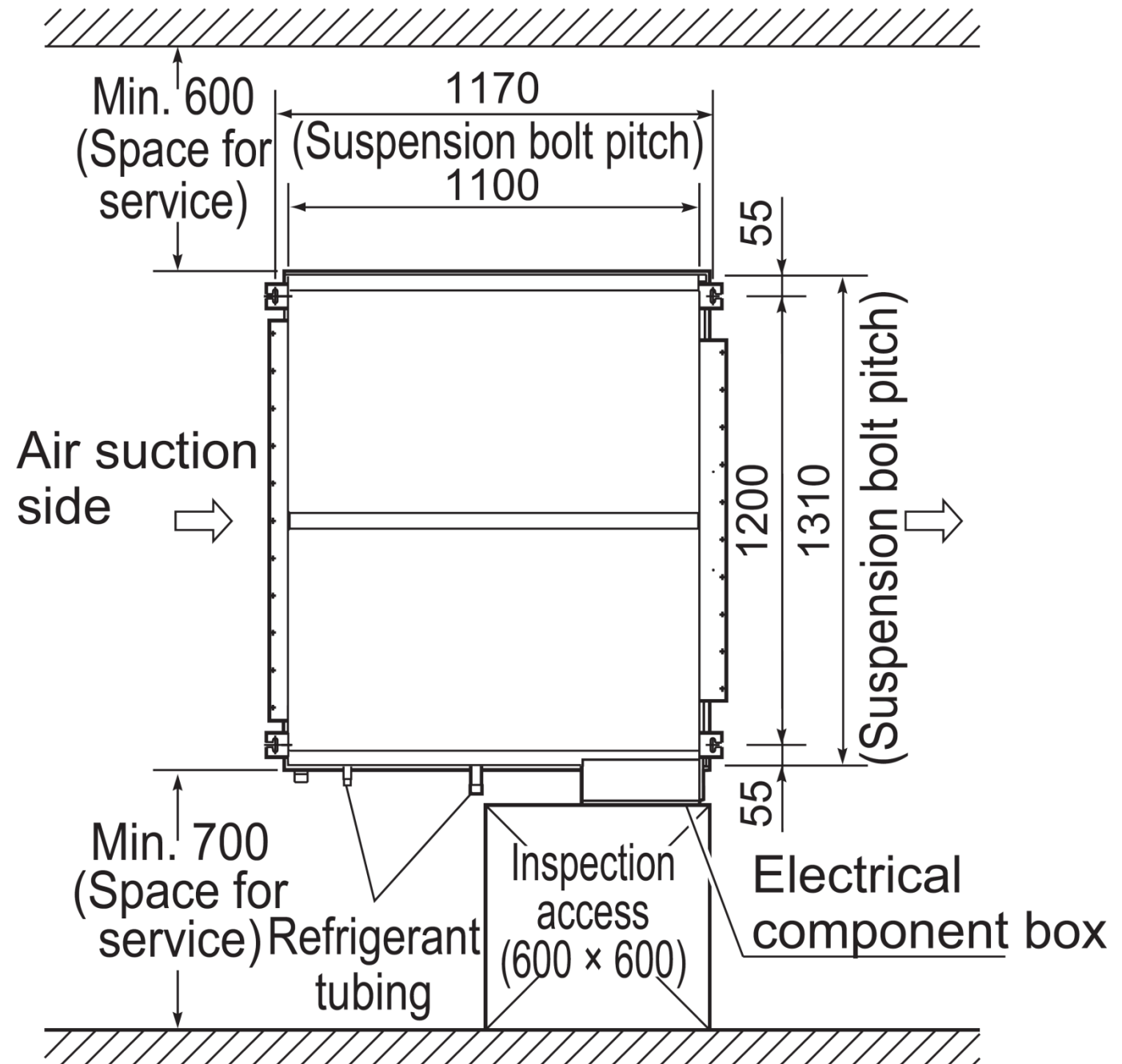
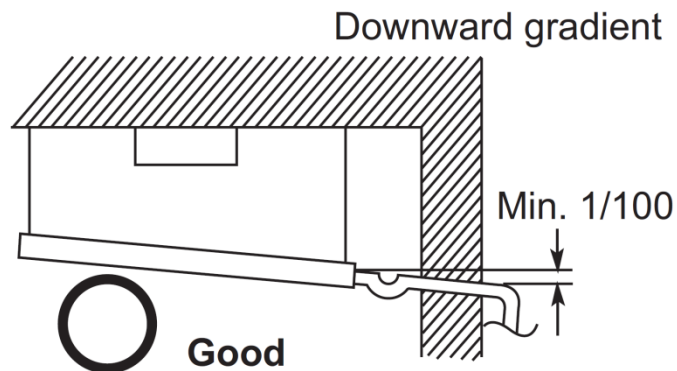
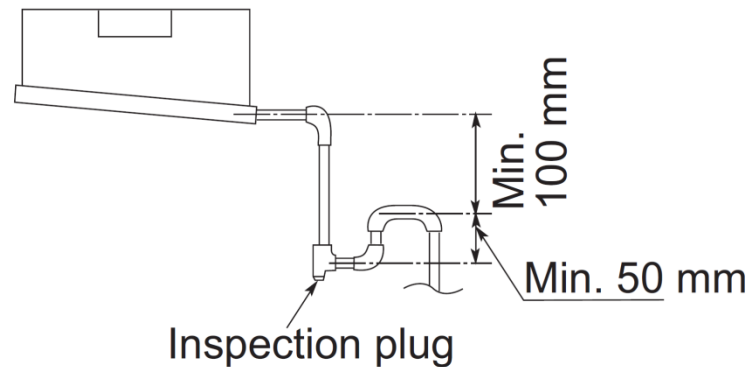
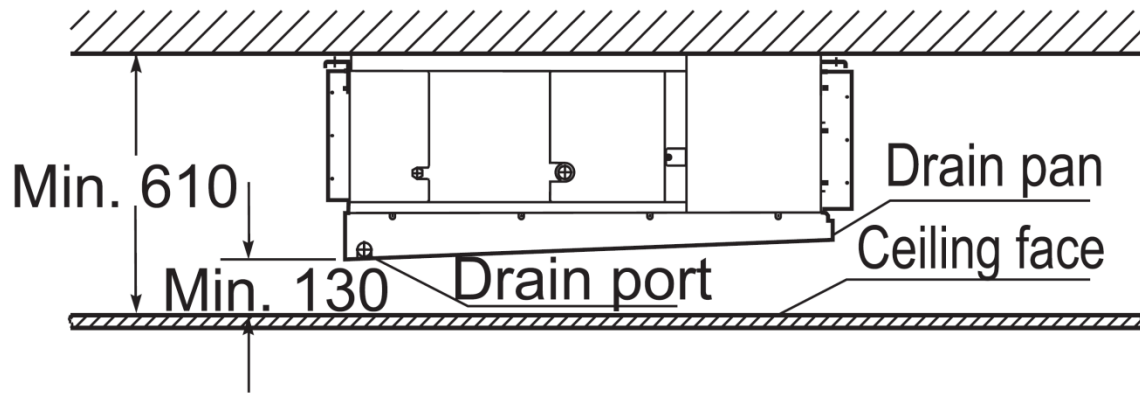

Wall Mounted Type (K1 Type) 22, 28, 36 types      45, 56, 73, 106 types

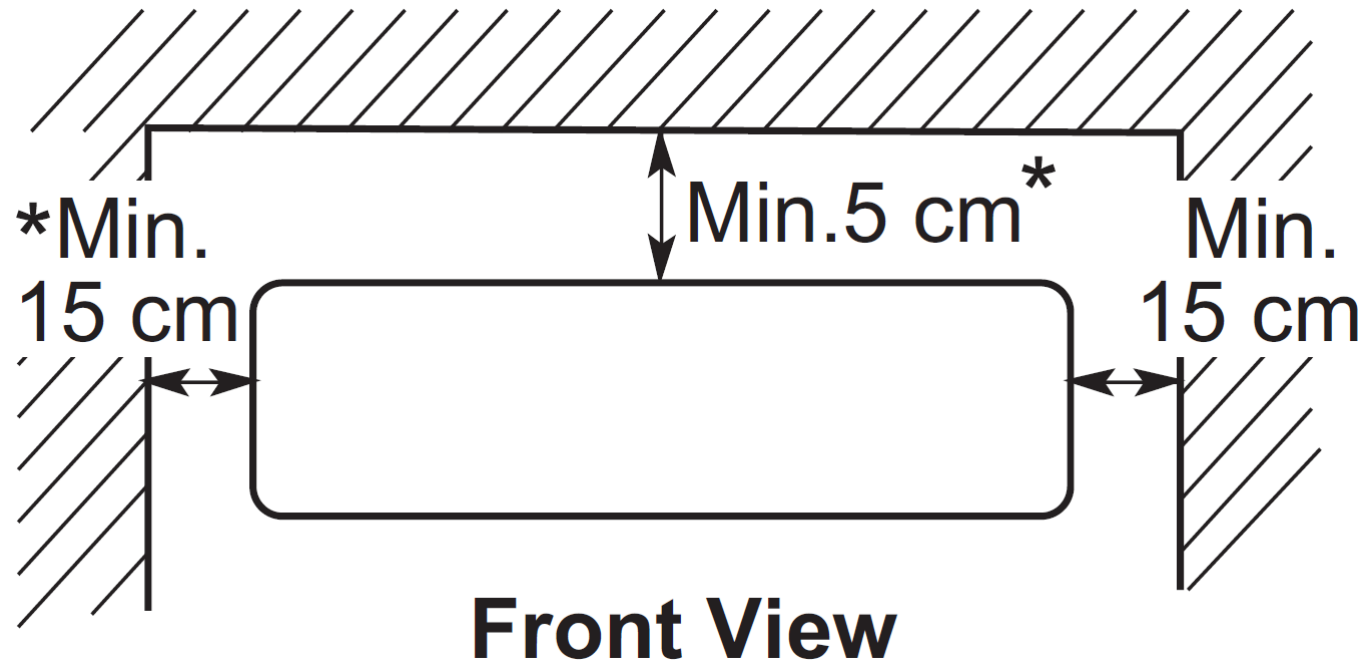

\* S-45MK1E5/56MK1E5/73MK1E5/106MK1E5 : Min. 7.5 cm

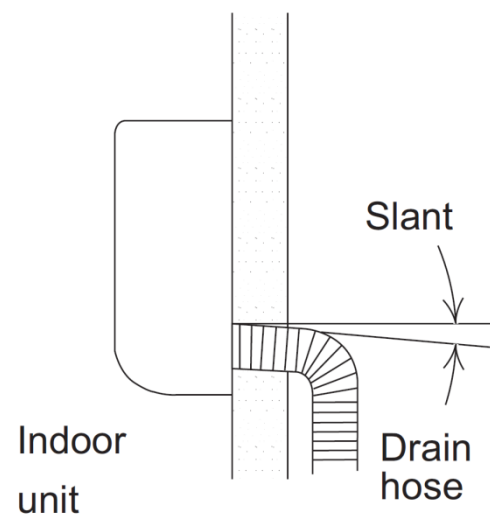

Floor Standing Type (P1 Type)

Concealed Floor Standing Type (R1 Type)

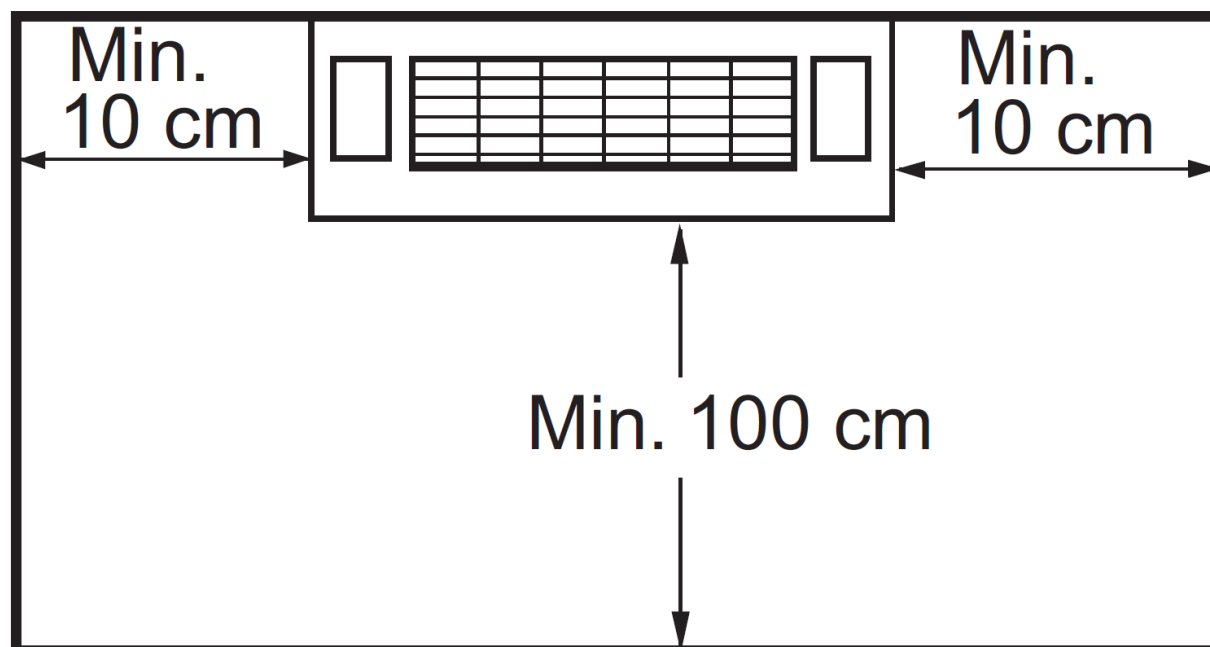

**Horizontal view**

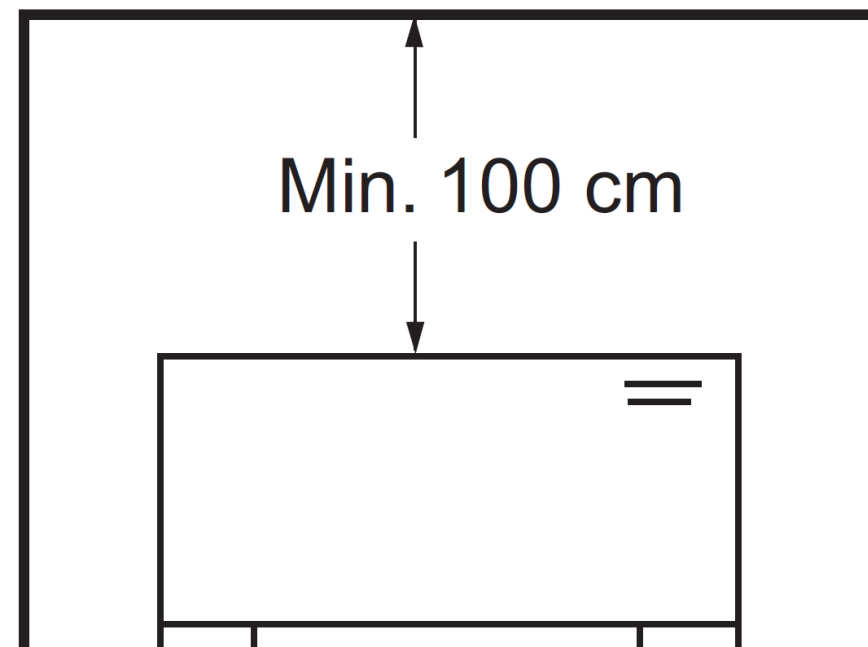

**Vertical view**

# ***Distribution joint kits***

### *Distribution Joint Kits*

Model name	Cooling capacity after distribution	Remarks
CR-P680PJ2	68.0Kw or less	For Outdoor Unit
CR-P1350PJ2	135.0Kw or less	
CZ-P160BK2	22.4Kw or less	For Indoor Unit
CZ-P680BK2	68.0Kw or less	
CZ-P1350BK2	168.0Kw or less	

### Installation Distribution Joint for **indoor** unit.

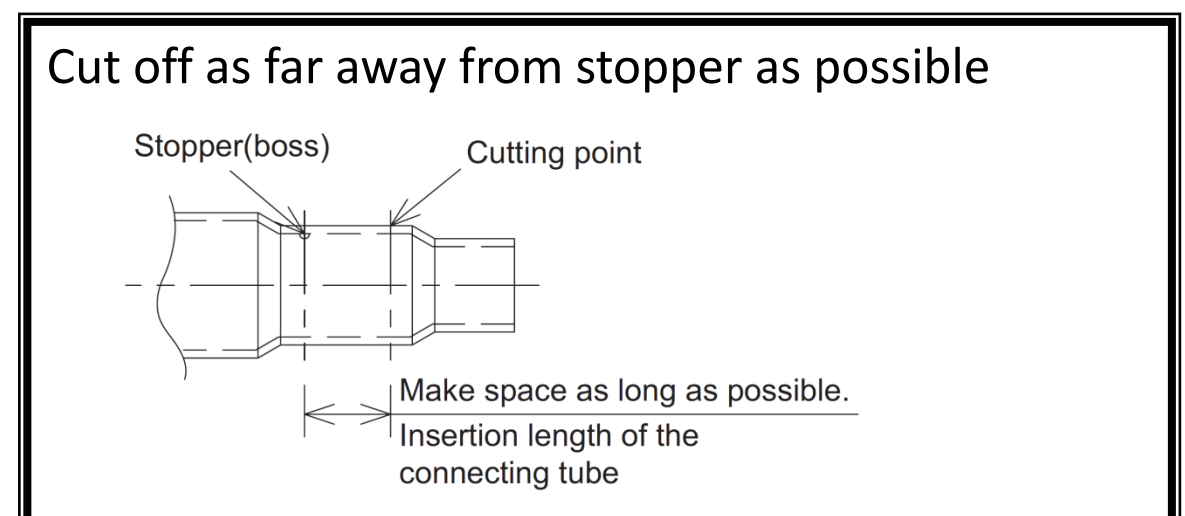
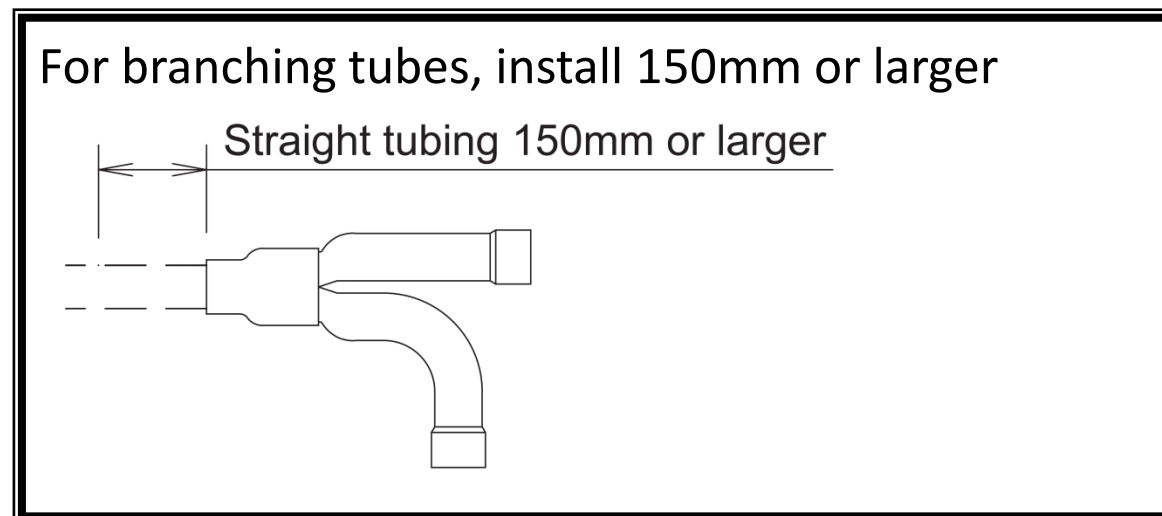
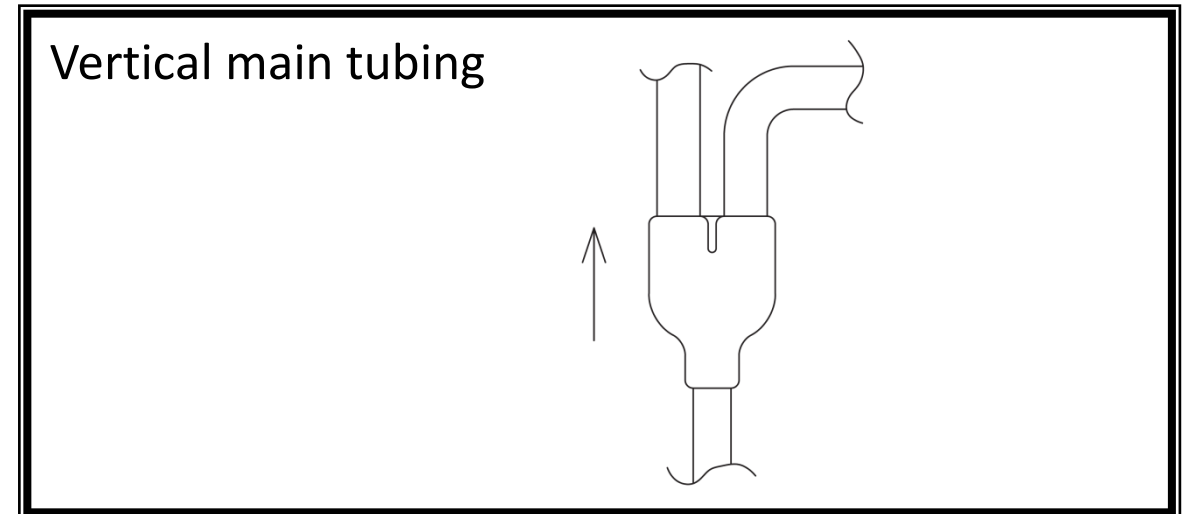
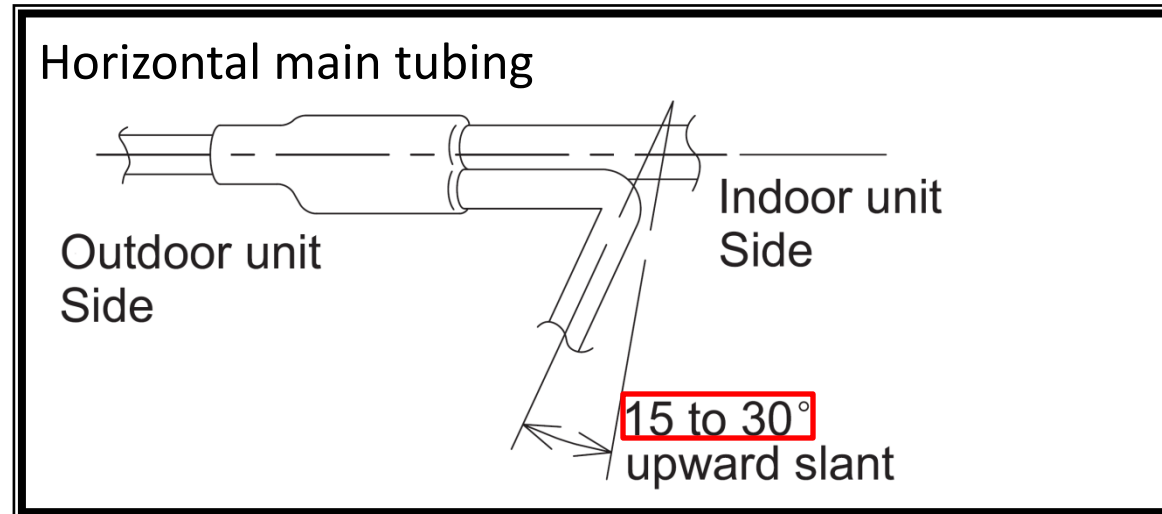

**Prevent accumulation of refrigerant oil in stopped units.**

### Installation Distribution Joint for **outdoor** unit.

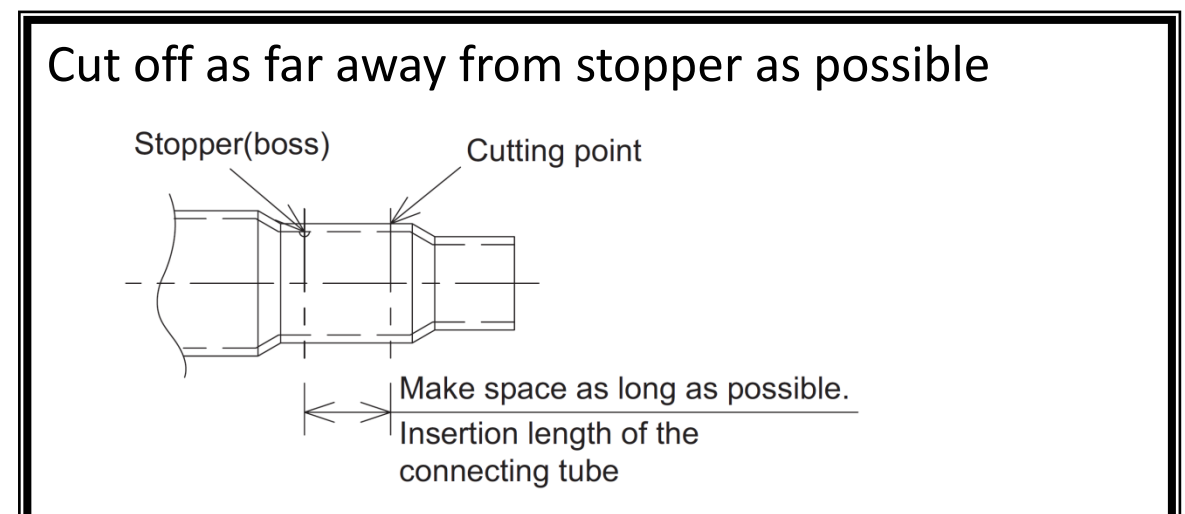
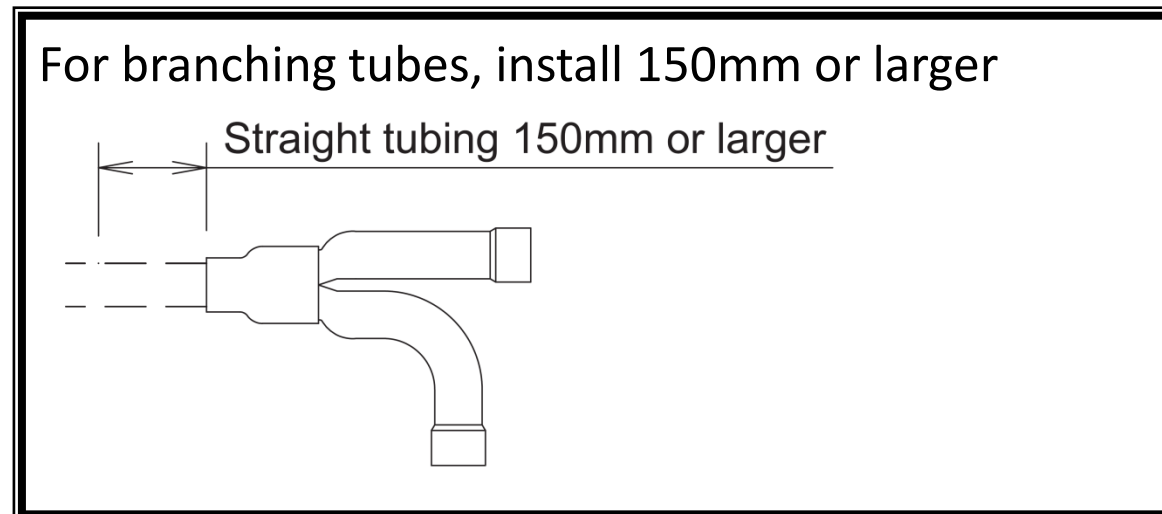
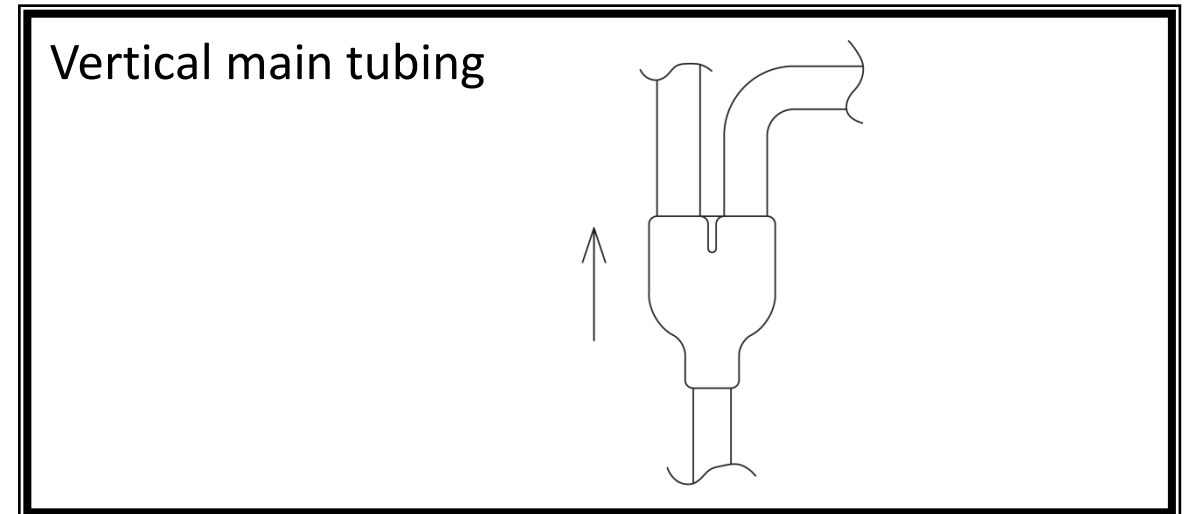
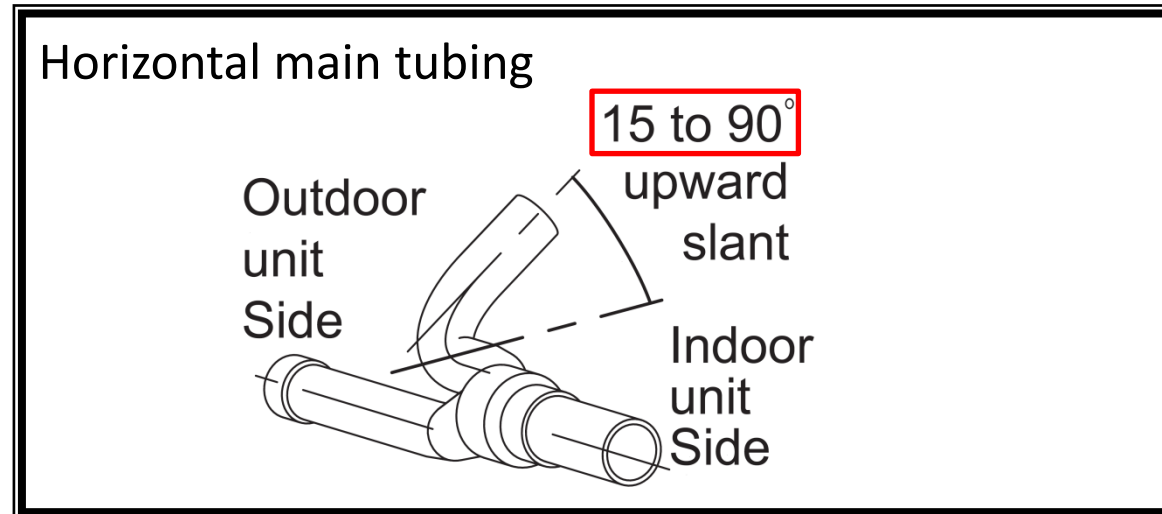

**Prevent accumulation of refrigerant oil in stopped units.**



Height differences between indoor units or branch tubing that follow a distribution joint is connected to only 1 unit. Ball valve or a trap must be added to that distribution joint.

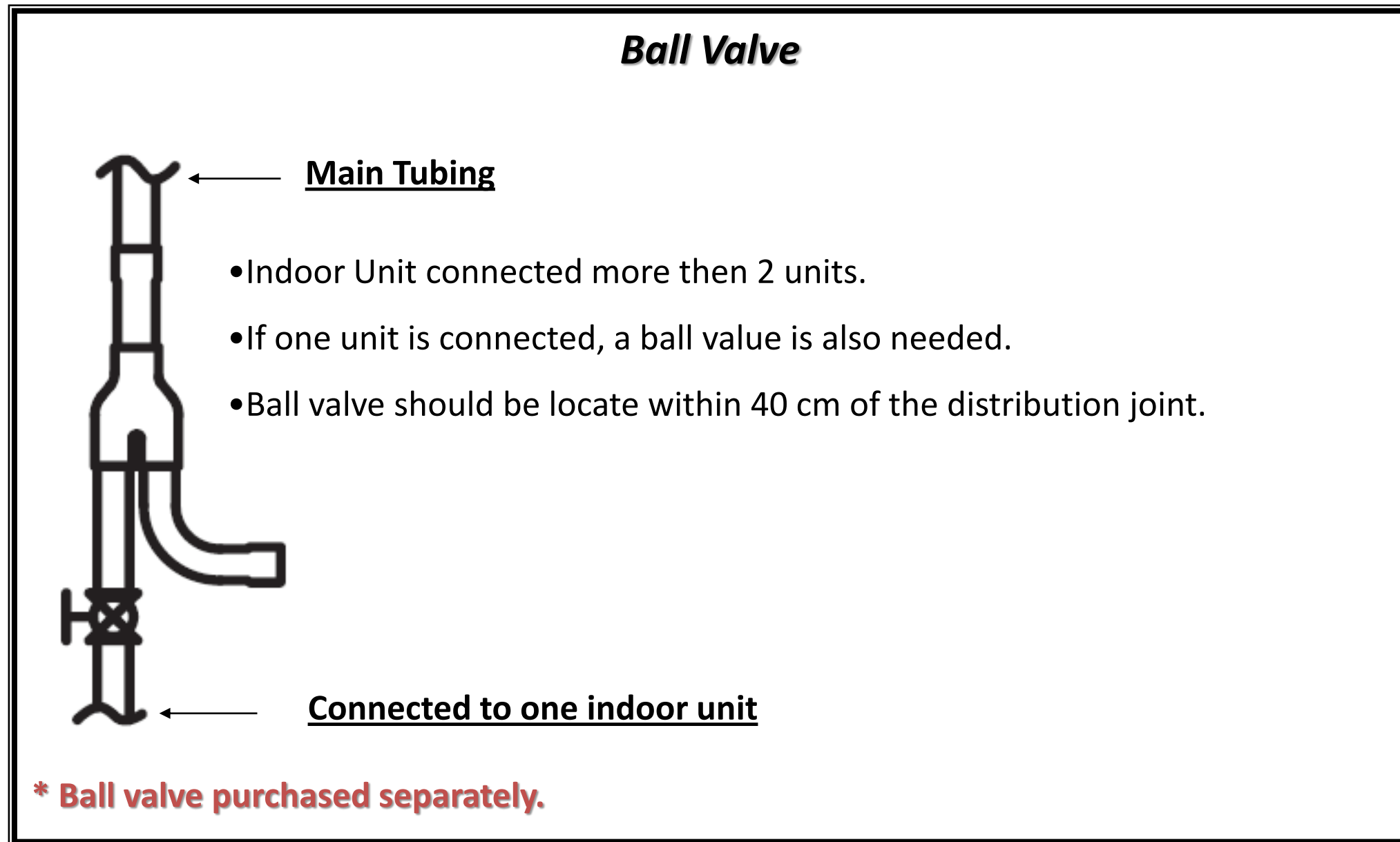

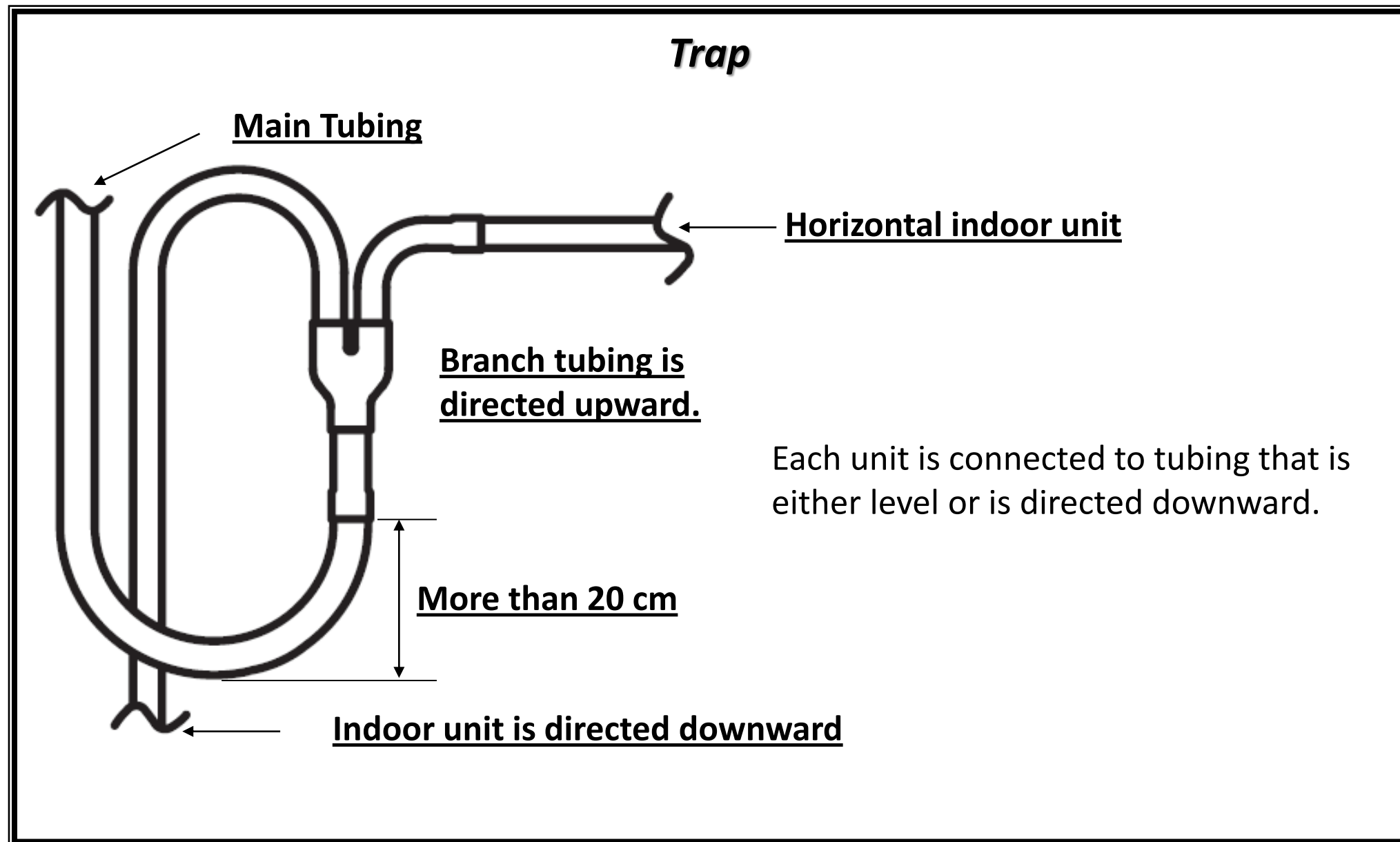

**NOTE**

If a trap or ball valve is not added, do not operate the system before repairs to a malfunction unit are completed. (The Refrigerant unit oil sent through the tubing to the malfunctioning unit will accumulate and may damage the compressor.)

# ***Drainage work***



### ***Models with Drain Pump***

- 1-Way Cassette (D1 Type)
- 2-Way Cassette (L1 Type)
- 4-Way Cassette (U1 Type)
- 4-Way Cassette 60×60 (Y1 Type)
- Low Silhouette Ducted (F2 Type)
- Slim Low Static Ducted (M1 Type)

### ***Models with Without Drain Pump***

- Wall Mounted (K1 Type)
- Ceiling (T1 Type)
- High Static Pressure Ducted (E1 Type)
- Floor Standing (P1 Type)
- Concealed Floor Standing (R1 Type)

### ***With Drain Pump Type D1, L1, U1, Y1, F2 AND M1***

- Insert the drain pipe until it contacts the socket, ensure secure it tightly with the hose band
- Do not use adhesive when connecting the supplied hose.

- Reasons:
1. It may cause water to leak from the connection is slippery just after the adhesive has applied the pipe slips off.
  2. The pipe will be difficult to remove when maintenance is needed.

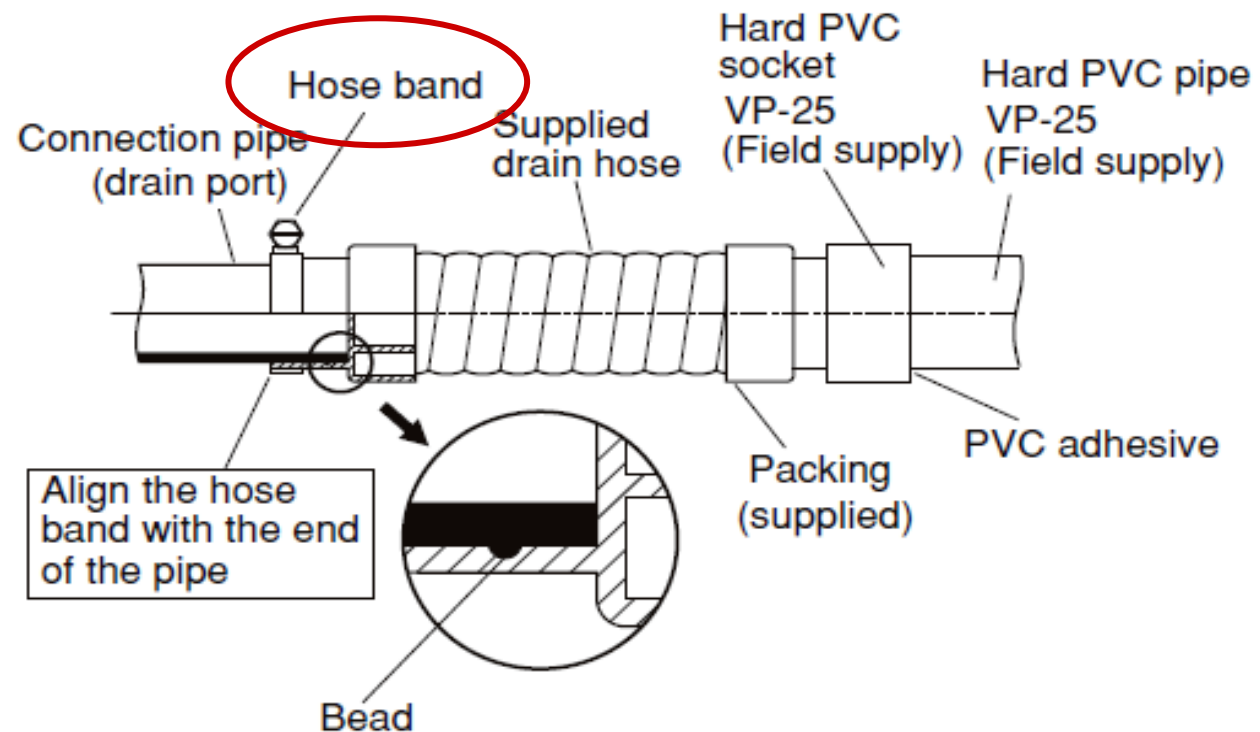

### ***With Drain Pump Type D1, L1, U1, Y1, F2 AND M1***

- Do not install the pipe with an upward gradient from the connection port.

This will cause the drain water to flow backward and leak when the unit is not operating.

- Do not bend the supplied drain hose 90° or more. The hose may slip off.

- Do not apply force to the piping on the unit side when connecting the drain pipe. The pipe should not be allowed to hang unsupported from its connection to the unit. Fasten the pipe to a wall, frame, or other support as close to the unit as possible.

- Do not install an air bleeder as this may cause water to spray from the drain pipe outlet.

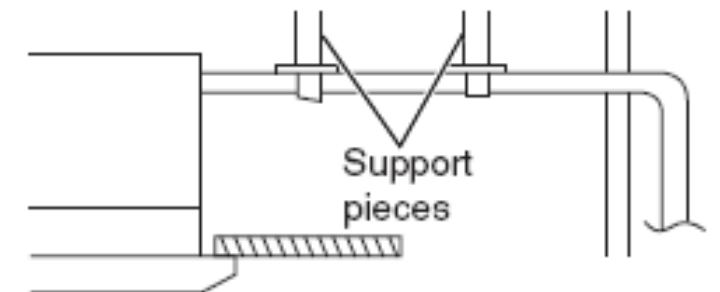
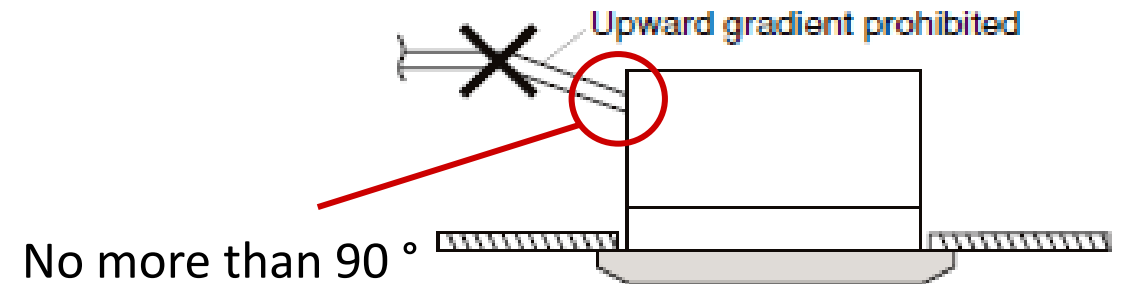

### ***Without Drain Pump Type for K1, T1, E1 P1 AND R1***

- Insert the drain pipe until it contacts the socket, ensure secure it tightly with the hose band.
- Do not install the pipe with an upward gradient from the connection port. This will cause the drain water to flow backward and leak when the unit is not operating.
- Do not apply force to the piping on the unit side when connecting the drain pipe. The pipe should not be allowed to hang unsupported from its connection to the unit. Fasten the pipe to a wall, frame, or other support as close to the unit as possible.

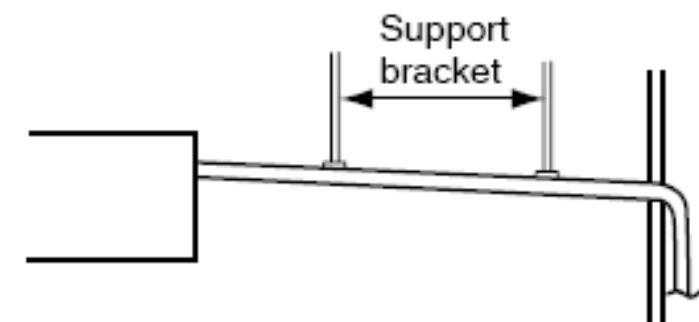
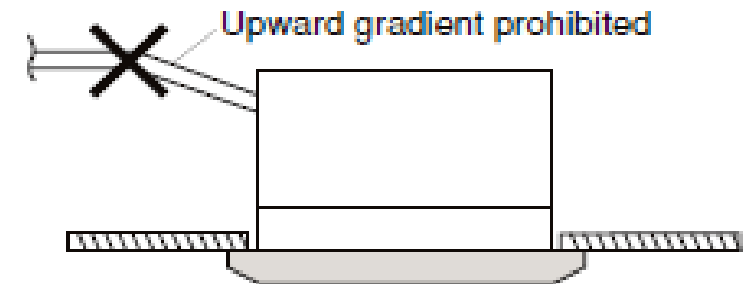
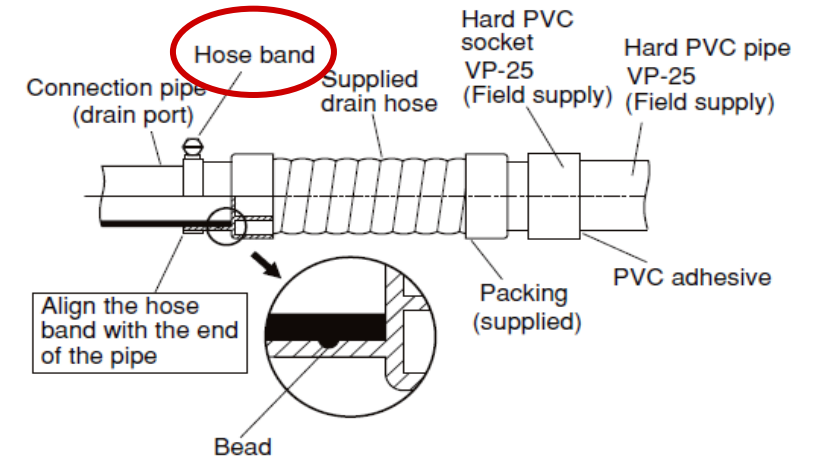

# ***Electrical wiring***



### NOTE

- Do not supply power to the unit until all wiring and tubing are completed or reconnected and checked.
- Highly dangerous electrical voltage are used in this system.
- Carefully refer to the wiring diagram and instructions manual when wiring.
- Improper connections and grounding can cause accidental injury or death.
- Ground the unit following your local electrical codes.
- Connect all wiring tightly. Loose wiring may cause overheating at connection point and a possible fire hazard.

### *Shielded Wire*

Use shielded wires for inter-unit control wiring and ground the shield on both sides, otherwise improper operation from noise may occur.

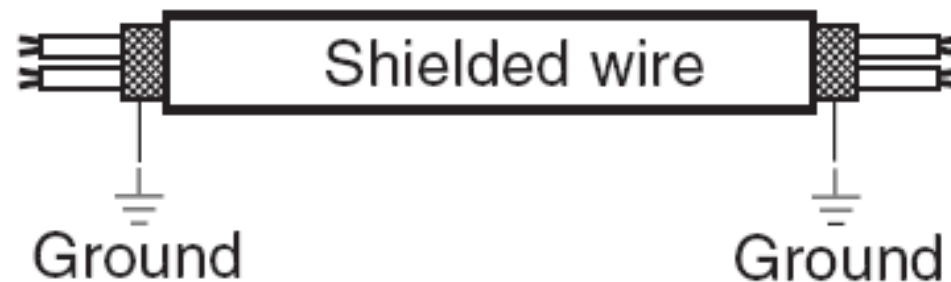

### WARNING

Loose wiring may cause the terminal to overheat or result in unit malfunction. A fire hazard may also exist. Therefore, ensure that all wiring is tightly connected.

### How to connect wiring to the terminal

Cut the wire end with cutting pliers, then strip the insulation to expose the wiring about 10mm and tightly twist the wire ends

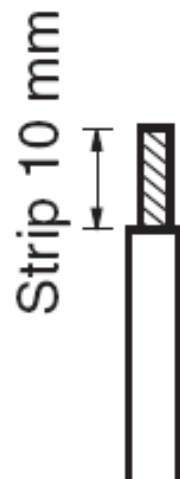

Using a ring connector faster or pliers, securely clamp each stripped wire end with a ring pressure terminal.

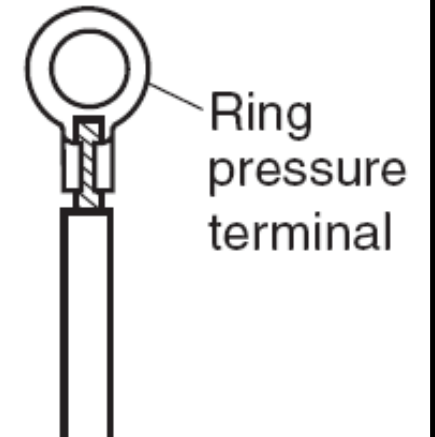

Place the ring pressure terminal, and replace and tighten the removed terminal screw using screwdriver.

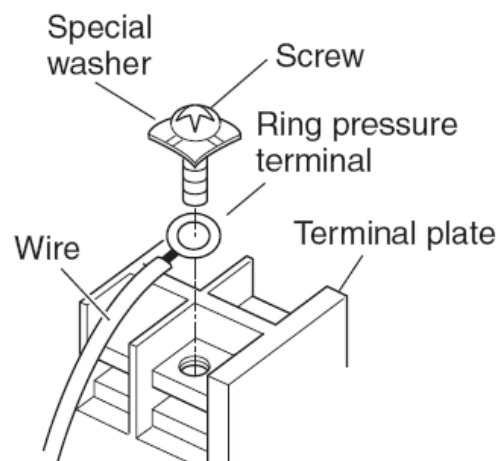

Using a Phillips head screwdriver, remove the terminal screw on the terminal plate.

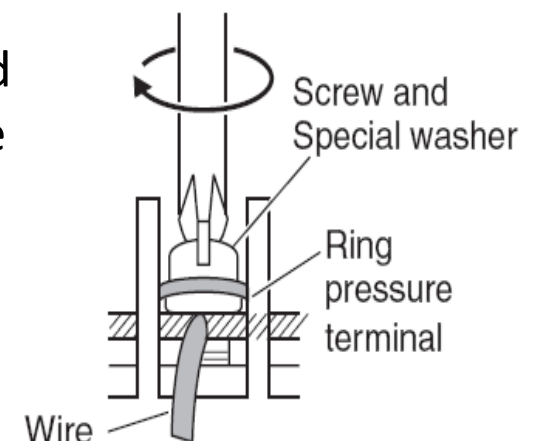

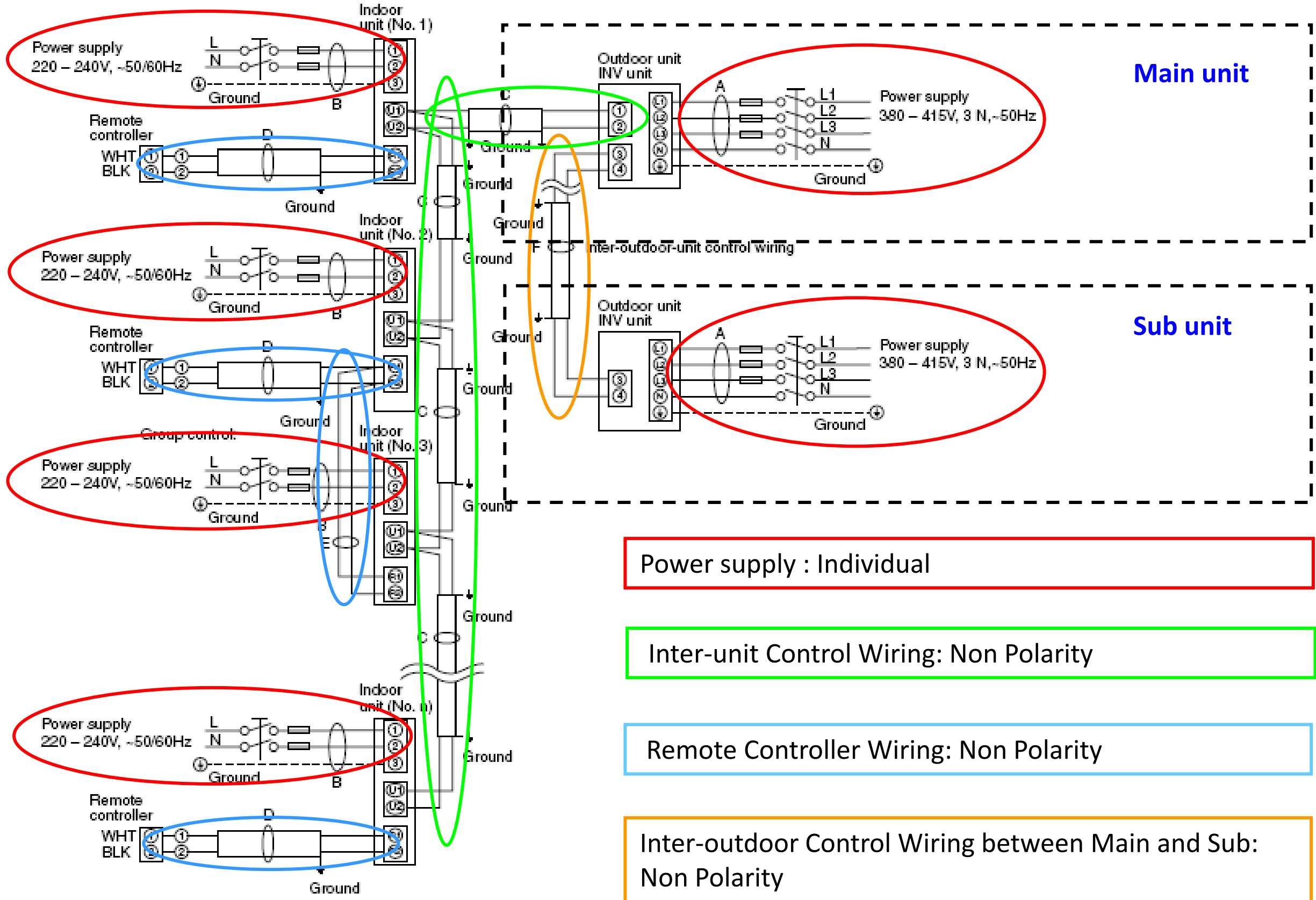

Power supply : Individual

Inter-unit Control Wiring: Non Polarity

Remote Controller Wiring: Non Polarity

Inter-outdoor Control Wiring between Main and Sub: Non Polarity

### Recommended outdoor unit wire length and wire diameter for power supply system

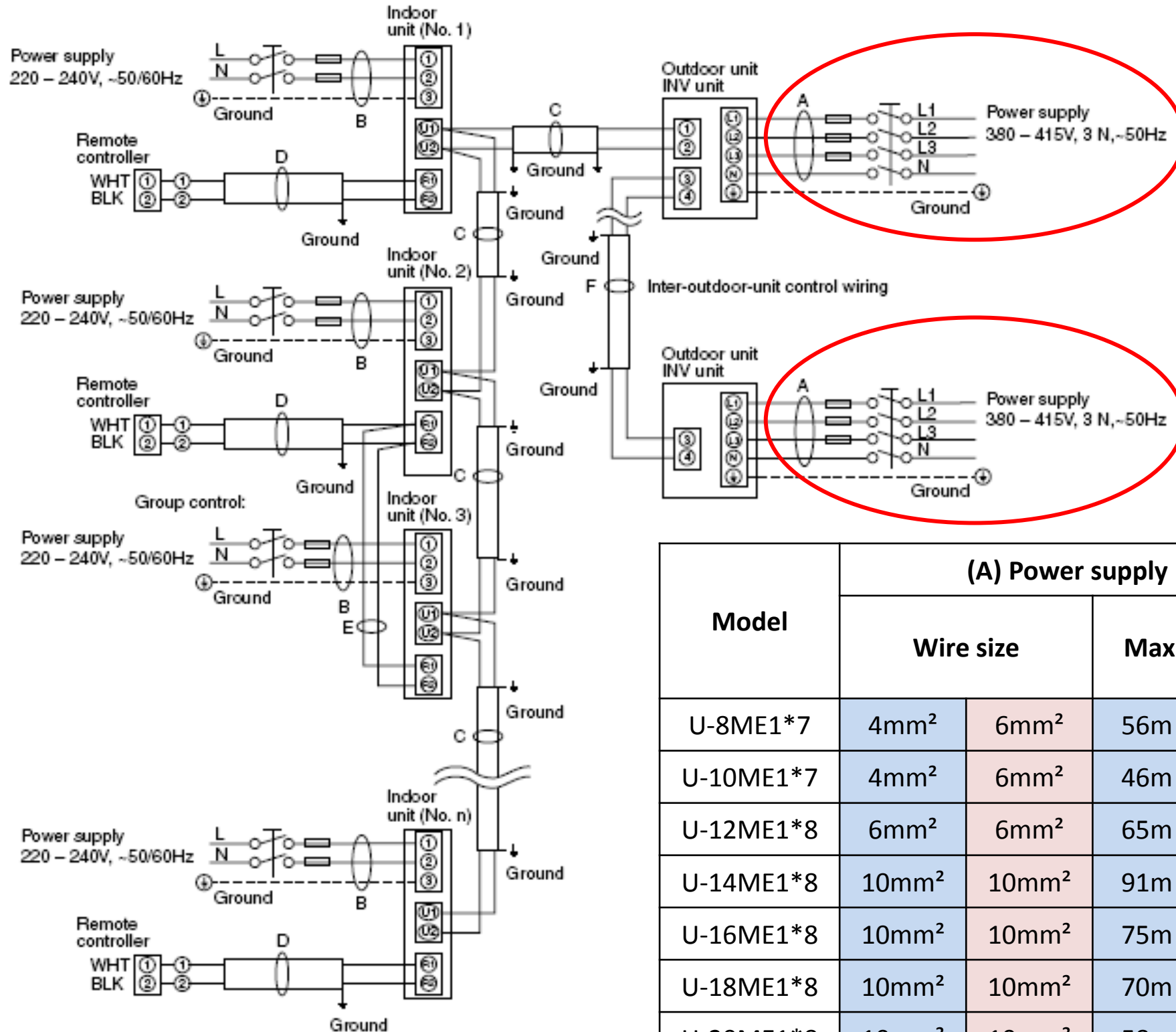

Model	(A) Power supply				Time delay fuse or circuit capacity	
	Wire size		Max. length			
U-8ME1*7	4mm <sup>2</sup>	6mm <sup>2</sup>	56m	84m	25A	35A
U-10ME1*7	4mm <sup>2</sup>	6mm <sup>2</sup>	46m	69m	25A	35A
U-12ME1*8	6mm <sup>2</sup>	6mm <sup>2</sup>	65m	65m	35A	35A
U-14ME1*8	10mm <sup>2</sup>	10mm <sup>2</sup>	91m	91m	35A	50A
U-16ME1*8	10mm <sup>2</sup>	10mm <sup>2</sup>	75m	75m	45A	50A
U-18ME1*8	10mm <sup>2</sup>	10mm <sup>2</sup>	70m	70m	50A	50A
U-20ME1*8	10mm <sup>2</sup>	10mm <sup>2</sup>	58m	58m	50A	50A

### Recommended indoor unit wire length and wire diameter for power supply system

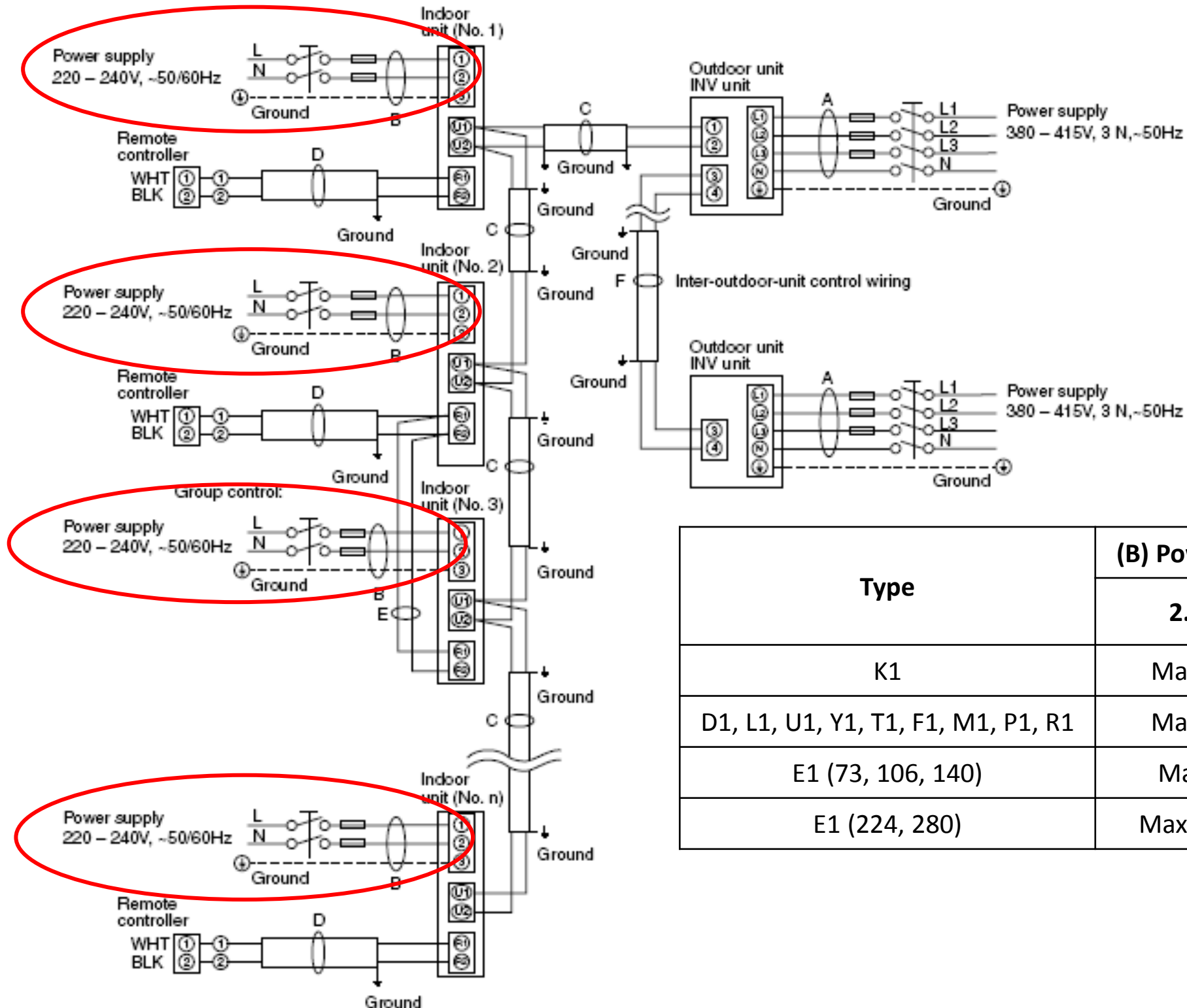

Type	(B) Power supply	Time delay fuse or circuit capacity
	2.5mm <sup>2</sup>	
K1	Max. 150m	<b>10 ~ 16A</b>
D1, L1, U1, Y1, T1, F1, M1, P1, R1	Max. 130m	
E1 (73, 106, 140)	Max. 60m	
E1 (224, 280)	Max. 50/30m	

### Recommended control wiring wire length and wire diameter for power supply system

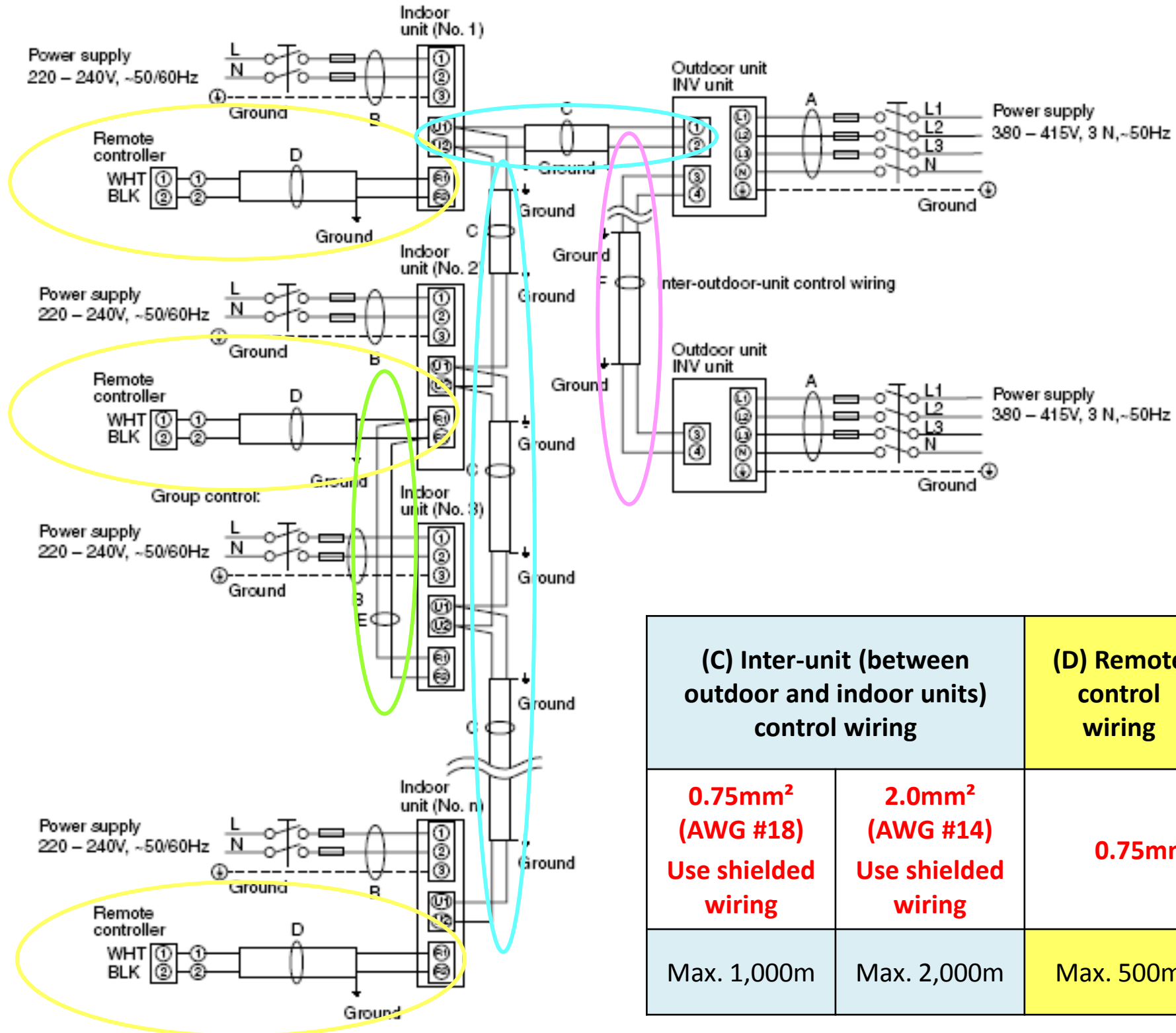

(C) Inter-unit (between outdoor and indoor units) control wiring	(D) Remote control wiring	(E) Control wiring for group control	(F) Inter-outdoor unit control wiring
<b>0.75mm<sup>2</sup> (AWG #18)</b> <b>Use shielded wiring</b>	<b>2.0mm<sup>2</sup> (AWG #14)</b> <b>Use shielded wiring</b>	<b>0.75mm<sup>2</sup> (AWG #18)</b>	<b>0.75mm<sup>2</sup> (AWG #18)</b> <b>Use shielded wiring</b>
Max. 1,000m	Max. 2,000m	Max. 500m	Max. 300m

Do not connect such as **loop wiring** & **star wiring**.

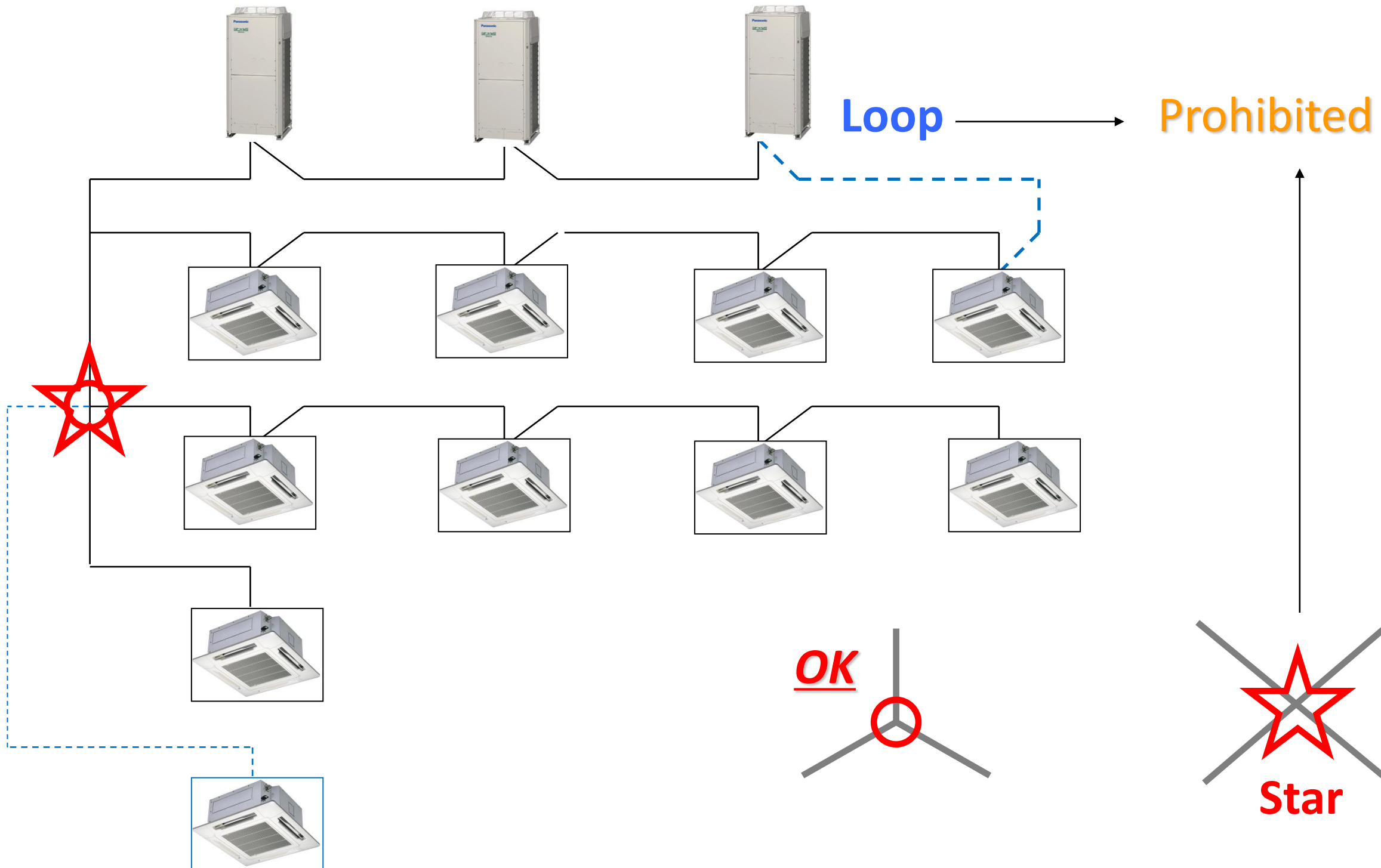

### Up to 3 outdoor units & 64 indoor units

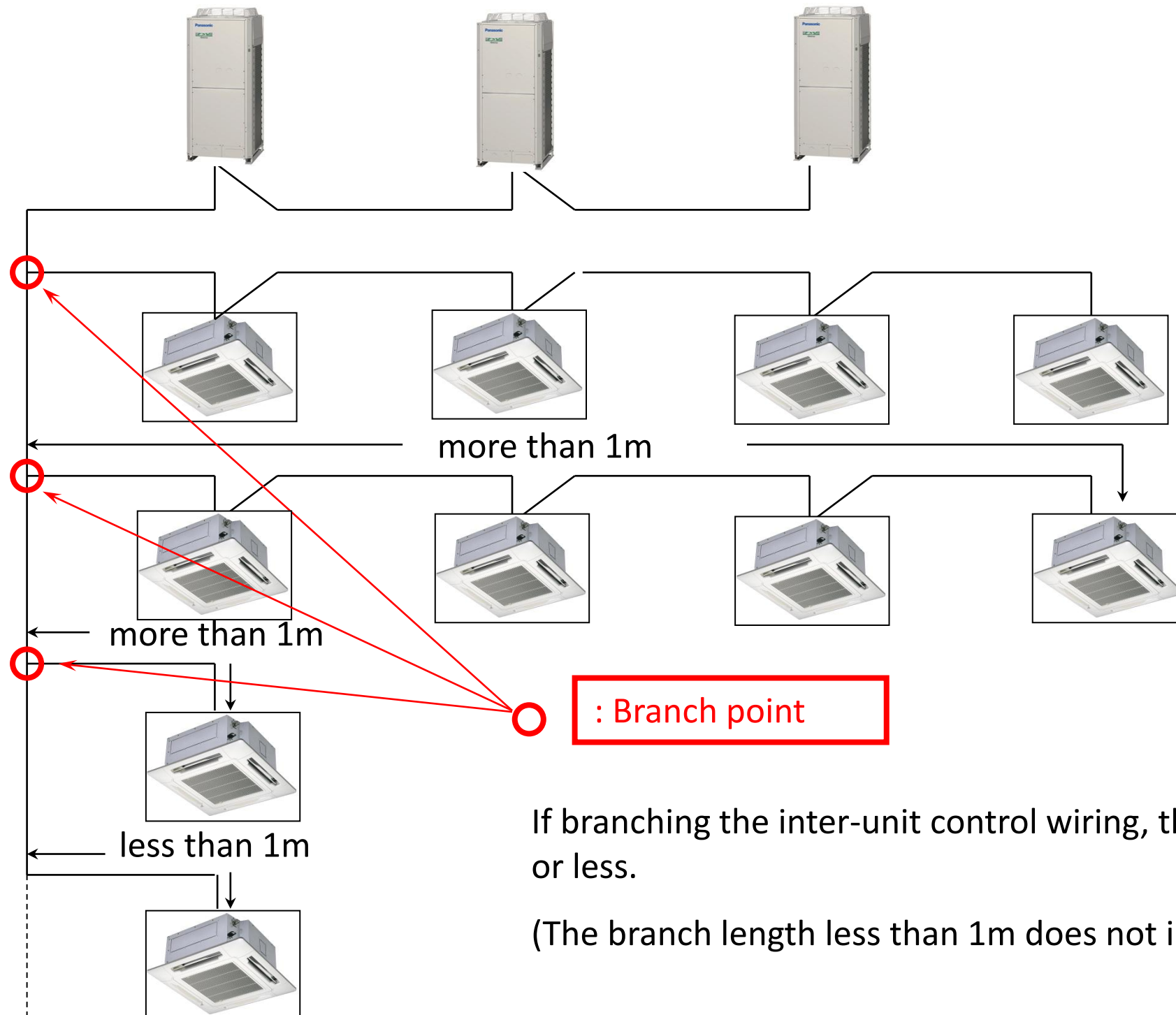

If branching the inter-unit control wiring, the No. of branch point should be 16 or less.

(The branch length less than 1m does not include the branch No.)



***Thank you.***

Copyright Panasonic corp.  
Internal use only.

Transfer is not permitted.

No part of this document may be reproduced or transmitted in any form or by any means without prior permission from Panasonic.